

## Development of GaN-FET Based 12V/48V Converter

Lee Seung Jun<sup>1</sup>, Lee Sang Hyeok<sup>1</sup>, Jeong Doo Ho<sup>1</sup>

<sup>1</sup>*KyungShin Corp., 98, Gaetbeol-ro, Yeonsu-gu, Incheon, Republic of Korea, kei94420@kyungshin.co.kr*

---

### Summary

This paper proposes 12V-48V converter based on GaN-FET and confirms its benefits as an automotive converter. GaN-FET, next generation switch, features high-speed switching, and it allows the inductor to be designed in small size. To confirm this benefit, inductor designed for high-speed switching is fabricated and compared with convince inductor designed for normal-speed switching. This converter is developed as a vehicle product. So, it communicates with ECU via the CAN communication to get an Mild Hybrid System energy-information before operation of power conversion. Depending on the amount of the holding energy in system, the power conversion's directions and capacities are determined. To verify converter's benefits and functions, 12V-48V converter based on GaN-FET is fabricated and experimented by prototype converter. To demonstrate the superiorities of high-speed switching, power conversion efficiencies are measured at 300kHz.

*Keywords: GaN-FET, 12V-48V Converter, Bidirectional Converter, Automotive Converter, Power Conversion, Mild-Hybrid System, Mild-Hybrid Vehicle.*

---

## 1 Introduction

In automotive industry, environment-friendly automobiles have been being developed. This is because fuel efficiency regulations, which are one of the conditions for selling cars, are becoming strict. To satisfy fuel efficiency regulation, automobiles that use electrical energy as a source of motor power are being developed. However, this system requires a lot of energy to drive motor, and it is difficult to supply sufficient energy with the conventional energy system which has a 12-Volt-battery and 14-Volt-generator.

Recently, to overcome this energy shortage, an alternative which raises the system voltage level to 48V is getting attention. In general, increasing the voltage magnitude in a system allows a lot of energy to be supplied. Figure 1 shows the handling limit energy of 12V and 48V systems. At 290-Ampere, 48-Volt system can supply energy up to 14kW, which is four times larger than 12-Volt system.

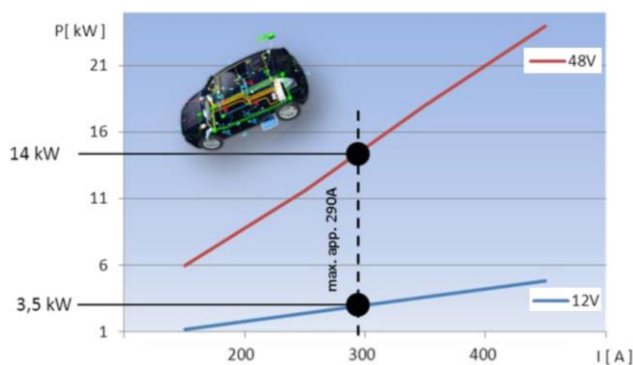

Figure1: Supply of Additional Power at 48V <sup>[1]</sup>

Actually, in the past, the automotive industry had tried to apply a 48V system to the vehicle. But it failed because they were trying to replace the entire 12V system with 48V and faced difficulties that all existing components had to be newly developed for use in 48V systems. Now, considering cost aspect, Mild-Hybrid System, which has both 12V and 48V systems, has emerged. This new system is highly feasible because only components that require a lot of energy can be selectively developed as 48V components. Because it can raise fuel efficiency with reasonable cost, automobile manufacturers are applying Mild-Hybrid System for their vehicle.

The Mild Hybrid System, consisting of dual voltage, requires a converter to transfer energy between system, and this converter should have good power conversion efficiency. Thus, this paper describes the GaN-FET based bidirectional converter in the Mild-Hybrid System. Application of GaN-FET to converter is a major feature whose benefits will be discussed concretely. With simulation, prototypes was fabricated to verify the merits of the proposed converter, and its validity was confirmed through experiments.

## 2 48V Mild-Hybrid System

The Mild-Hybrid System is divided into 48V system and 12V system depending on the voltage level. As shown in Figure 2, the 48V system includes a 48V battery, a motor-generator and loads. The 12V system includes a 12V battery, a starter, and loads. Here, the 48-volt system should supply a large amount of energy to loads, so a lithium-ion battery with the advantages of high energy density and light weight is applied.

In Mild-Hybrid System, the converter performs a very important role which transfers the energy between two systems. In addition, converters for vehicles should include safety, reliability, stability, and communication functions. However, it is not easy to make the converter which has those functions. In this regard, the converter developed by Kyung-Shin will be discussed. It includes those functions and can transfer the energy both directions in Mild-Hybrid System.

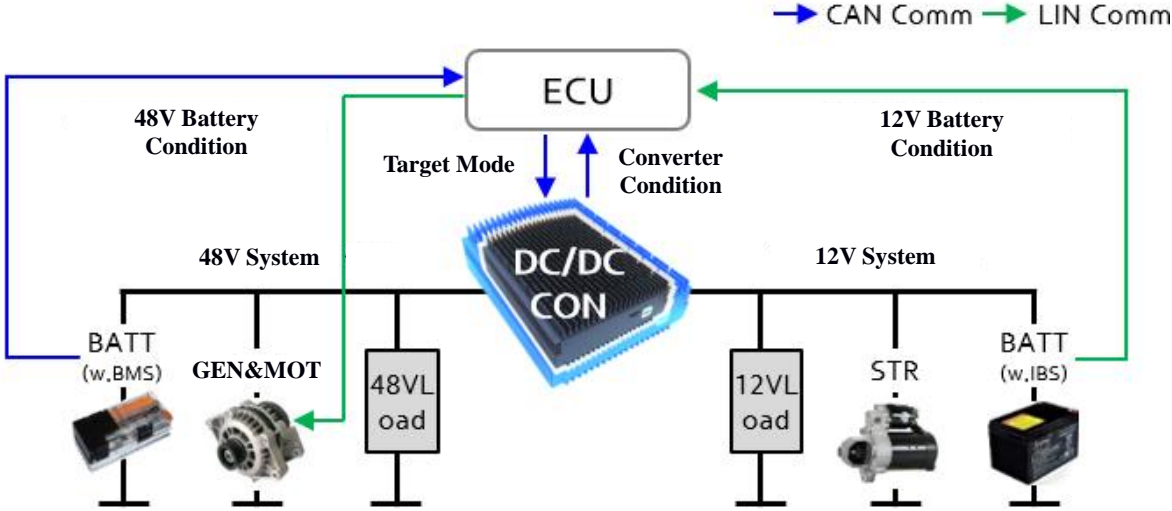

Figure 2. 48V Mild Hybrid System

### 2.1 Bidirectional 12V/48V Converter

The dc-to-dc power conversion is broadly referred to as the process of generating a desired dc voltage using a dc source whose voltage level is different from the desired value: namely, changing the voltage level of a dc source into another value. In figure2, the bidirectional converter performs power conversion from 48V to 12V or 12V to 48V. In other words, this converter ensures that the energy of both systems keeps sufficient. Also, this converter anticipates demand of energy and responds in advance. This energy prediction can be possible by communicating with an upper level supervisor ECU.

### 2.1.1 Power Conversion Functions

This 12V-48V converter can transfer the energy to both sides. But, this converter usually transfers the energy from 48V system to 12V system because of the BSG which is the energy source located at 48V system. This mode is like a buck converter and called as buck mode. On the contrary, if it is impossible that the 48V Lithium-ion battery alone supplies sufficient energy to 48V System, the energy transmission from the 12V System to the 48V System occurs. For example, in very cold weather, battery voltage level drops significantly low. At this time, boost mode, called as emergency mode, is needed. Because of the low voltage level 12V, large current flows where high power conversion occurs. If power conversion is performed at 2.5kW level, a current of 170-Ampere flows through the converter. This is one of the problem that makes converter design difficult. To overcome this, converter takes an interleaved structure. This interleaved structure distributes a large amount of current in parallel, and reduces a current to flow in each phase of power conversion circuit. It allows converter to be designed with reasonable price device.

### 2.1.2 Functions required for Automotive 48V Converter

As shown in figure2, the converter in Mild Hybrid System is directly connected to the batteries. If something unexpected happens, huge current can flows through the converter. So, converter includes short circuit protection function with Back-to-Back switch which placed between the power stage circuit and the battery. If some problem occurs in the converter or the batteries, Back-to-Back switch disconnects power line immediately.

A battery keeps electric energy in cells. But, if it is neglected for a long time, user should charge the battery with jumper cable directly. However, if a driver connects the battery cables to the battery in reverse, huge current will flow through cable and it becomes a very dangerous situation. In order to eliminate this risk, protection switch is utilized for reverse connection safety. Additional protection features include Over Voltage Protection (OVP), Low Voltage Protection (LVP), Over Current Protection (OCP) and Over Temperature Protection (OTP).

The automotive converter must know the energy state of the system for various reasons. But, it is impossible for the converter to know the state of system energy alone. So, the converter communicates with ECU to exchange information via CAN communication to get the energy information. The converter has to check the state of system energy before power conversion will be performed. The following describes the communication between the converter and the ECU about driving the converter. First, the ECU collects the energy information of the Mild Hybrid System, and determine converter drive mode with collected information. On the contrary, the converter sends the information about condition of the converter like voltage, current, and temperature to the ECU. Figure 2 shows the flowchart of the CAN communication and the Target Mode, which is the command issued by the ECU.

Power conversion technology has been developed to minimize loss and miniaturize converters. These advantages are more prominent in automotive converters. The following explains why this is useful in automotive converters. Most of the losses in power conversion are dissipated into heat, and automotive converter has to pass the severe temperature test. In this way, a technique of minimizing the loss of heat is required. High-speed switching techniques can reduce the size of the converter. In particular, the largest inductor among the converter devices can be innovatively reduced. This miniaturization of the converter is a very useful technique to pass vibration tests. In order to realize the advanced power conversion technology, GaN-FET was adopted as a switching device. The following section describes GaN-FETs and explains the advantages of converter which operates at high frequency with GaN-FET.

## 3 GaN-FETs

GaN(Gallium Nitride) as a next-generation semiconductor has received much attention in the field of power electronics. In particular GaN is attractive for high-frequency, and high-temperature applications due to its WBG(Wide Band Gap), large critical electric field, high electron mobility, and reasonably good thermal conductivity[2][3]. GaN-FETs developed by commercializing GaN semiconductors have several advantages as power devices. In Section 3, the comparison of Si-MOSFET and GaN-FET explain its superiority as a power device. The converter with GaN-FET advantages is described in detail.

To compare GaN-FET and Si MOSFET, devices with the same capacity of drain-to-source voltage and continuous drain current were selected as shown in Table 1. The parameters that directly affect the switching losses are input capacitance, output capacitance, and reverse recovery charge. The most significant feature is that the reverse recovery charge is close to zero. Switching loss is determined by the current flowing through the switch  $I_{out}$ , the converter input voltage  $V_{in}$ , average rising time  $t_r$ , and the switching frequency  $f_{sw}$ .  $t_r$  is determined by the  $C_{ISS}$  and amount of current provided by the Gate Driver Circuit. It can be expected that the GaN-FET switching loss is smaller than that of the Si-MOSFET by equation (1) [4].

$$P_{switchingLoss} = 2(C_{oss}V_{in}^2 + V_{in}/_{out}t_r)f_{sw} \quad (1)$$

Table1: Major parameters of GaN-FET & MOSFET

Symbol	Description	GaN-FET (GS61008T)	Conditions (GS61008T)	Si MOSFET (BSC070N10NS3)	Conditions (BSC070N10NS3)
$V_{DS}$	Drain to source voltage	100V	$T_{case}=25^{\circ}C$	100V	$T_{case}=25^{\circ}C$
$I_D$	Continuous drain current	90A	$T_{case}=25^{\circ}C$	90A	$T_{case}=25^{\circ}C$
$R_{DS(on)}$	Drain-Source on-state resistance	7m $\Omega$	$V_{GS} = 6V,$ $I_{DS} = 27A$	6.3m $\Omega$	$V_{GS} = 10V,$ $I_{DS} = 50A$
$C_{ISS}$	Input capacitance	588pF	$V_{GS} = 0V,$ $V_{DS} = 80V,$ freq = 1MHz	3000pF	$V_{GS} = 0V,$ $V_{DS} = 50V,$ freq = 1MHz
$C_{OSS}$	Output capacitance	254pF		520pF	
$Q_G$	Gate charge Total	12nC	$V_{DS} = 50V,$ $I_D = 60A,$ $V_{GS} = 0$ to 6V	42nC	$V_{DS} = 50V,$ $I_D = 25A,$ $V_{GS} = 0$ to 10V
$Q_{RR}$	Reverse recovery charge	0C	-	112nC	$V_R = 50V,$ $I_F = 25A,$ $di_F/dt = 100A/us$
Volume	Package Volume	6.8x6.3x0.6 mm <sup>3</sup>	-	6.6x5.8x1.3 mm <sup>3</sup>	-

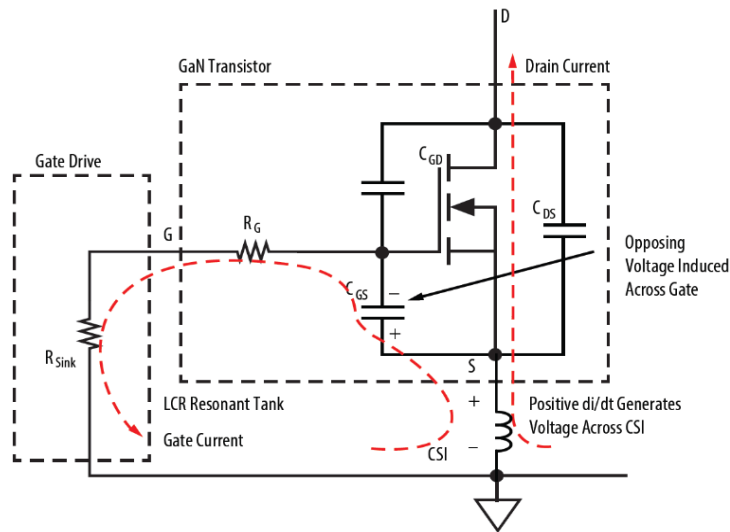

Figure4: Impact of a positive di/dt of an off-state device with common-source inductance[5].

### 3.1 GaN-FET Driving Circuit

A suitable gate driver is required for all switching operations. GaN-FETs also require a dedicated gate driver. The most distinctive feature of gate driver is a driving voltage. Where the gate drive voltage is between -2V and 0V, GaN-FET is turned-off. Where the gate drive voltage is between 5V and 6.5, GaN-FET is turned-on. Because of this lower gate voltage, noise minimization design is required. Figure4 shows the power stage loop and gate driver loop of the GaN-FET. These two loops are closely related to the efficiency and stability of the switch. In particular, 48V converters with high current flow can cause ringing noise to gate signals due to CSI (Common Source Inductance) and parasitic capacitance of GaN-FET. This noise not only lowers the efficiency, but it can also cause miller turn-on which can cause serious problems with the GaN-FET. Because the magnitude of the CSI is determined by the PCB routing, the designer has to pay attention to the PCB design.

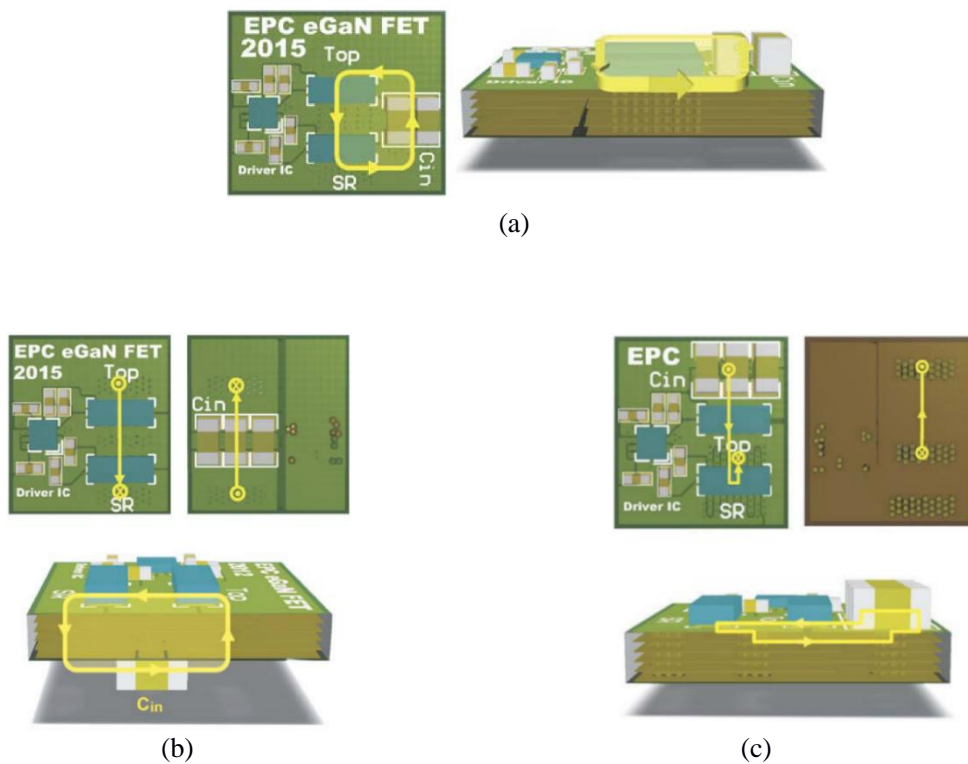

Figure5: Conventional and Optimized Power Loops with GaN-FETs: (a) Conventional lateral power loop for GaN-FET based Converter (b) Conventional vertical power loop for GaN-FET based Converter (c) Optimized vertical power loop for GaN-FET based Converter[6].

Table2: Characteristics of conventional and optimal power loop designs[6].

	(a) Lateral loop	(b) Vertical loop	(c) Optimal loop
Single-sided PCB capability	Yes	No	Yes
Magnetic field self-cancellation	No	Yes	Yes
Inductance independent of board thickness	Yes	No	Yes
Shield layer required	Yes	No	No

Table 2 describes the advantages that depend on PCB routing. The optimized power loop provides magnetic field self-cancellation and single-sided PCB capability. Inductance is also independent of board thickness and shield layer is not necessary.

### 3.2 High-speed Switching Frequency in DC/DC Converter

The representative advantages of GaN-FETs are that switching loss is small and high-speed switching is possible. The high-speed switching with GaN-FET reduces the size of the passive elements in the converter and is able to select low-cost devices. The largest volume element among the passive components in the converter is an inductor. This inductor is a key component of power conversion and can be designed to a significantly smaller size if the switching frequency is increased. In table 3, two inductors were compared to demonstrate the benefits of high-speed switching. The samples were selected to satisfy the similar condition where  $I_{ripp}$  is 4-Ampere,  $V_s$  is 48V. At 100 kHz (MOSFET) switching, a 21uH inductor should be used to flow the 4-Ampere ripple current. At 300kHz (GaN-FET) switching, a 7uH inductor should be used to flow the 4-Ampere ripple current. The above inductance is calculated by equation (2)[7]. Comparing the sizes of the two inductors, it can be seen that the volume reduction is about 68% at 300 kHz.

$$L = \frac{V_s}{I_{ripp} \times f_{sw}} \quad (2)$$

Table3: Comparison of Inductor Volume where Ripple Current was 4-Ampere

Inductor Series	Switch Type	Ripple Current	Inductance	$I_{SAT}$	Volume
Customized Inductor	GaN-FET	4A @ 300kHz	7uH	50A	<b>13.6 cm<sup>3</sup></b>
AGP4233 <sup>[8]</sup>	MOSFET	4A @ 100kHz	21uH	36.6A	<b>42.3 cm<sup>3</sup></b>

The high-speed switching also is able to select the low performance output capacitors. The product of ESR (Equivalent Series Resistance) in capacitor and ripple current is the loss consumed in the output capacitor, which is the criterion for selecting the capacitor. Increasing the switching speed proportionally reduces magnitude of the ripple current, which makes it possible to select an output capacitor with a higher ESR, lower cost, and a smaller output capacitor.

### 3.3 Operation Modes of the 48V Converter

Operation modes of the 48V converter are determined according to the state of the systems. The ECU first checks in real time whether the systems have sufficient energy, and gives mode information to drive the converter via CAN communication. Finally, converter operates in Buck, Boost, Passive, and Fail-Safety Modes.

#### 3.3.1 Buck Converter Mode

In Buck Converter Mode, the energy is transferred from 48V to 12V. The Buck Converter is a step-down converter that produces lower output voltage than the input voltage. As shown in Figure6, it can operate as CC (Constant Current), CV (Constant Voltage), and CP (Constant Power) Converter according to ECU command. If battery voltage level is below 7V or upper 15.5V, the converter falls in derating state or limited state. Because the energy source of the system is connected to the 48-Volt System, the converter maintains almost Buck Converter Mode.

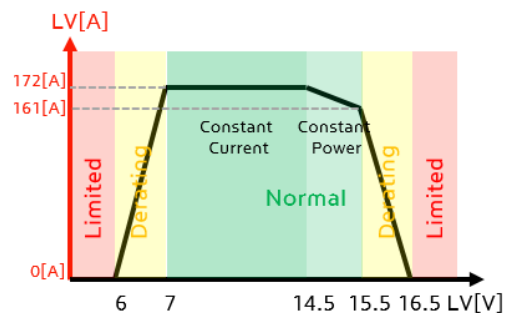

Figure6: Converter operating state according to battery voltage range at Buck Mode

#### 3.3.2 Boost Converter Mode

In Boost Converter Mode, energy is transferred from 12V to 48V. The boost converter is a step-up converter that produces higher output voltage than the input voltage. As shown in Figure7, it can operate as CC (Constant Current), CV (Constant Voltage), CP (Constant Power), and Derating Converter according to ECU command. If battery voltage level is below 36V or upper 52V, the converter falls in derating state or limited state. This mode provides the required energy from the 12-Volt System to 48V System when the 48-Volt System can't supply enough energy.

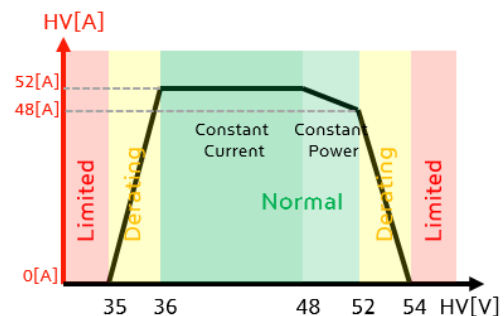

Figure7: Converter operating state according to battery voltage range at Boost Mode

#### 3.3.3 Fail-Safety Mode

Fail-Safety Mode is intended to protect the system in the event of unexpected problems. If Over Current, Over Voltage, Under Voltage, Over Temperature, Under Temperature occur, the converter electrically isolates between the 12V system and the 48V system in an instant by turning off the protection switches.

#### 3.3.4 Passive Mode

At Passive Mode, the converter maintains a standby state without performing power conversion. There is no need to transfer energy, this mode is performed. Also, a mode change occurs, passive mode is performed. Both the protection switches and the main switches are turned off in this mode.

### 3.4 Simulation to verify power and mode conversion

As shown in Figure8, Converter topology was adopted to perform bidirectional power conversion and 4-phase structure was adopted for current distribution. In Figure8 (a), C Block functions as a digital controller. It is possible to implement digital control system and algorithm with C-block as in the real system at simulation. In order to achieve the same condition as the practical converter, a circuit for inputting dead time is implemented in the simulation. In figure8 (b-c), Simulation waveforms verify the reliability of the algorithm for changing the power conversion mode and the Constant Current Control. The reliability of the mode conversion algorithm can be confirmed by Figure8 (b). Figure8 (d) shows the current ripple in the inductor. This 4-ampere ripple current means that the converter is driven at 300kHz with a 7uH inductor. Also, Figure8 (d) shows the 4-phase interleaved operation. This interleaved structure produces a low output current ripple, which reduces the stress of the output capacitor.

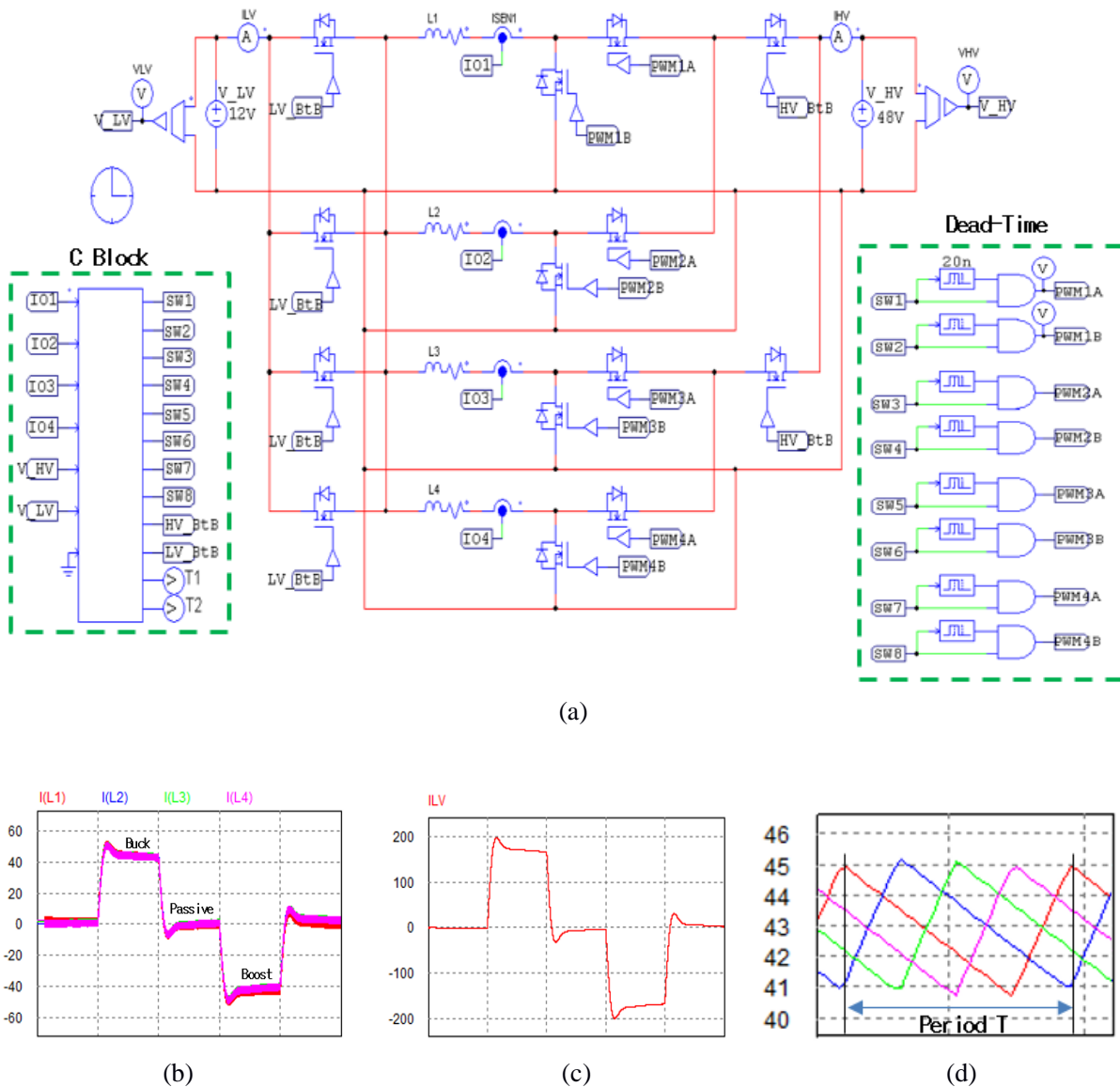

Figure8: Schematic and Current waveforms to Verify Power and Mode Conversion: (a) Schematic for 48V Converter Simulation (b) 4-Phase Inductor Current to verify the Mode Conversion (c) 12-Volt Output Current (d) Interleaved Inductor Current

### 3.5 Operation Program for Practical Test

This program was designed for convenience of development. According to the command by ECU, the 48V converter determines the power conversion direction and capacity. Figure9 is a converter test program that can give a drive command to the converter. Also, this program features includes checking the major voltage and current levels in real time. The major voltage, current can be displayed by this program, and also, the user can issue commands to the converter by pressing the buttons which are LV BtB, HV BtB, Buck Mode, and Boost Mode. To determine the power conversion capacity, user can put the average inductor current value into the program.

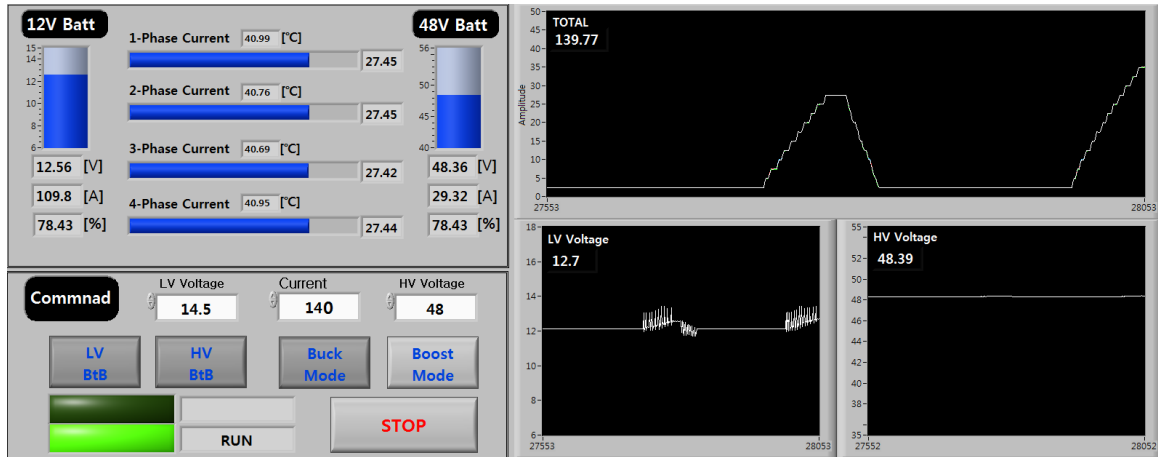

Figure9: Converter Operation Program

## 4 Prototype Converter

### 4.1 Specification of the 48V Converter by Kyung-Shin Corp.

As shown in Figure10, GaN-FET based 48V converter was developed by Kyung-Shin Corp. The outline of the converter and development specifications are as follows. This converter features include 2.5kW class rated power, Bidirectional power conversion, and Digital PI control.



<b>Weight</b>	1.85kg
<b>Volume</b>	185x120x90 mm <sup>3</sup>
<b>Phase</b>	4-Phase
<b>Rated Power</b>	2.5kW
<b>Operation Voltage Range</b>	LV : 6[V] ~ 16.5[V] HV : 34[V] ~ 54[V]
<b>SW Frequency</b>	300kHz
<b>Cooling System</b>	Active Air Cooling
<b>Power Direction</b>	Bidirectional Conversion
<b>Inter-face</b>	CAN
<b>Controller</b>	MCU 32 bit

Figure10: GaN-FET based 48V Converter made by Kyung-Shin Corp.

## 4.2 Practical Experiment

Figure 11 shows the major waveforms and efficiency where the 48-Volt Converter is in Buck Converter Mode. Figure(A) demonstrates that the converter operates at rated power 2.5kW. Figure (B) shows the efficiency measured by WT3000. In all operation regions, efficiency of more than 95% was achieved.

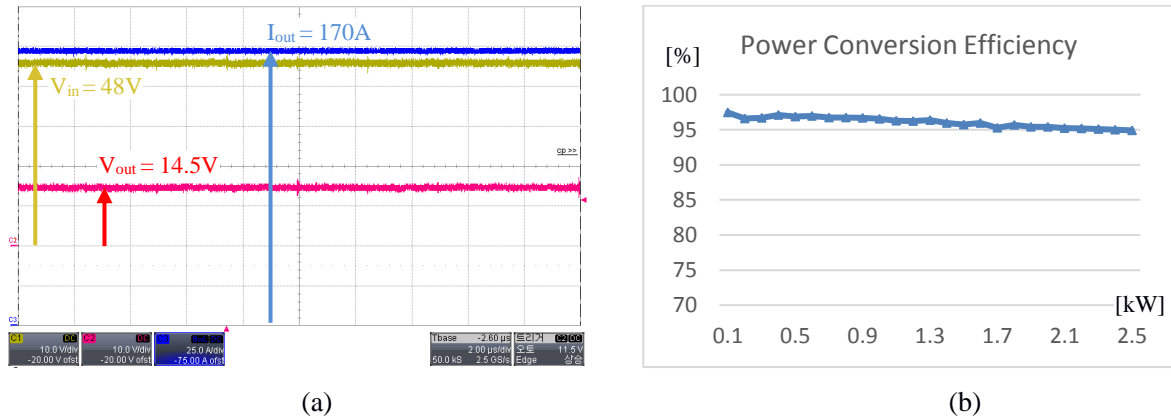

Figure11: Power Conversion at Buck Converter Mode :

(a) In/Output Voltages & Output Current Waveforms (b) Power Conversion Efficiency

## 5 Conclusion

In this paper, bidirectional 12V-48V converter based on GaN-FET was represented. This converter developed by Kyung-Shin Co., Ltd., features high-speed switching and was confirmed by test with practical converter. The 300kHz switching drive, which is three times higher than conventional converter, made converter reduced. Especially, the size of inductor was reduced up to 68%. Also, at 300kHz switching, power conversion efficiencies higher than 95% were achieved in power conversion regions from 100W to 2.5kW. The functional tests for automotive converter were implemented by SW program such as safety, CAN communication, change of the power conversion capacity, and direction.

## References

- [1] Kuypers, M., *Application of 48 Volt for Mild Hybrid Vehicles and High Power Loads*, SAE Technical Paper, 2014
- [2] J. Millan, P. Godignon, X. Perpina, A. Perez-Tomas, and J. Rebollo, *A Survey of Wide Bandgap Power Semiconductor Devices*, IEEE Transactions on Power Electronics, 0885-8993, May 2014, 2155-2163
- [3] Jerry L. Hudgins, *Power Electronic Devices in the Future*, IEEE Journal of Emerging and Selected Topics in Power Electronics, 2168-6777, March 2013, 11-17.
- [4] C. P. Henze, H. C. Martin, and D. W. Parsley, "Zero-Voltage-Switching in high frequency power converters using pulse width modulation," IEEE Applied Power Electronics Conference and Exposition, 0000-0033, 1988, 33-40
- [5] J. Strydom, D. Reusch, S. Colino, A. Nakata, *Using Enhancement Mode GaN-on-Silicon Power FETs, Efficient Power Conversion*, 2014, 1-9
- [6] A. Lidow, J. Strydom, M. de Rooij, *GaN Transistors for Efficient Power Conversion: Second Edition*, ISBN 1-118-84476-9, Wiley, 2015.
- [7] Byungcho Choi, *Pulsewidth Modulated DC-to-DC Power Conversion Circuits, Dynamics, and Control Design*, ISBN 978-1-118-18063-1, Wiley, 2013, 39-45.
- [8] Datasheet, *TH Power Inductors-AGP4233*, Coilcraft, 2017.

## Authors



**Seung Jun Lee** received his B.S. in electronics engineering from Kumoh National University, Gumi, Korea, in 2012 and M.S. in Power electronics from Kyungpook National University, Daegu, Korea, in 2016. From 2012 to 2014, he was a Research Engineer with Silicon Display Company, Yongin, Korea. In 2016, he joined Kyungshin corp., as a Research Engineer in Electric Power & Material Research Team. His current research interests include Automotive Converters, Inverters, and Power Conversion for Electric Vehicles.



**Sang Hyeok Lee** received his B.S. and M.S. degrees in Control and Measurement Engineering from Hanbat National University, Daejeon, Korea, in 2007 and 2009, respectively. He received his Ph.D degree in Electrical Engineering from Chonnam National University, Gwangju, Korea, in 2012. From 2013 to 2015, he was a senior engineer with the Power Electric Division, LS Automotive Company Ltd., Anyang, Korea. His current research interests include Bidirectional converter, Low DC/DC Converter and Automotive applications.



**Doo Ho Jeong** received his B.S. in electronics engineering from Dankook University, Yongin, Korea, in 2012. From 2011 to 2015, he was a Battery Management System Research Engineer with Nexcon Technology Company, Cheonan, Korea. In 2015, he joined Kyungshin corp., as a Research Engineer in Electric Power & Material Research Team. His current research interests include automotive converters, inverters, and power conversion for electric vehicles.