

*EVS30 Symposium
Stuttgart, Germany, October 9 - 11, 2017*

Comparison of power electronics solutions to exchange energy between high voltage batteries

Laurent Garnier, Daniel Chatroux, Julien Dauchy

Laurent Garnier: laurent.garnier@cea.fr,

Univ. Grenoble Alpes, F-38000 Grenoble, France

CEA, LITEN, DEHT, SAMA, LAEH F-38054 Grenoble, France

Executive Summary

Electrification of always more powerful systems is usually correlated to higher needs in reliability, service continuity and energy exchanges between sources. In the field of energy storage systems, these needs are often addressed by parallelization of batteries, which are automatically disconnected in case of fault. The service continuity is thus simply ensured. If the disconnection of two batteries in parallel is an instantaneous process well controlled, the connection is a longer process more complicated, which requires adapted power electronics solutions. Based on a concrete case of application and thanks to simulations, we propose in this paper to compare different solutions to exchange energy between two lithium ion battery systems.

This question has been addressed in the framework of a H2020 European project named ESPRIT “Easily Distributed Personal Rapid Transit”. In the first part of the paper we will present the project and more precisely the societal benefits, the main objectives and the first important results. The second part of the paper will deal with the comparison of power electronics solutions designed to exchange energy between batteries.

Keywords: Li-Ion battery, power exchange converters, energy storage



1 Presentation of ESPRIT project

1.1 Aims of ESPRIT project

The “Easily diStributed Personal Rapid Transit” (ESPRIT) H2020 project aims to develop a purpose-built, light weight, L category electric vehicle that can be stacked together to gain space. Thanks to pioneering coupling systems, up to 8 ESPRIT vehicles can be nested together in a road train, seven being towed, for an efficient redistribution of fleets and a smartly-balanced and cost efficient transport system. During redistribution or parking, energy can be exchanged between vehicles to maximize and secure the state of charge of the first vehicles which will be taken first by a user.

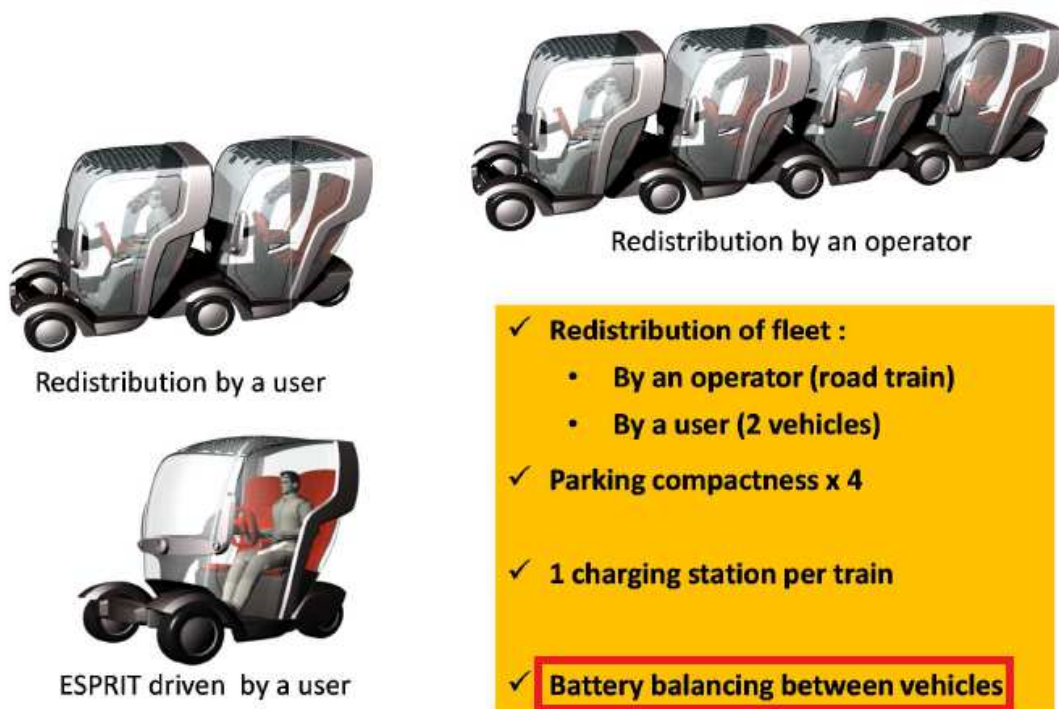

Figure 1 - Aims of the ESPRIT project

1.2 Societal benefits

It is anticipated that this concept will encourage citizens to use conventional public transport and carsharing solutions rather than their private vehicles leading to seamless intermodal transport, reduced congestion and significant reduction of noise and air pollution. As the key to the ESPRIT transport system is the ability to redistribute 8 vehicles at a time by a single operator, the project expects to demonstrate through simulation that it is possible to achieve a continuous 90% availability rate of vehicles across all stations (in last kilometre and one-way carsharing mode) using less manpower compared to current systems which have 50% of stations empty several times a day.

2 Power electronics problem presentation

Inside each electric vehicle presented just above, we have a battery system and a power exchange solution to balance energy between vehicles. The objective is to maximize and secure as far as possible the state of charge of the first vehicle of the road train because it will be the first one to leave the charging station. We can thus optimize the availability of a charged vehicle for the user.

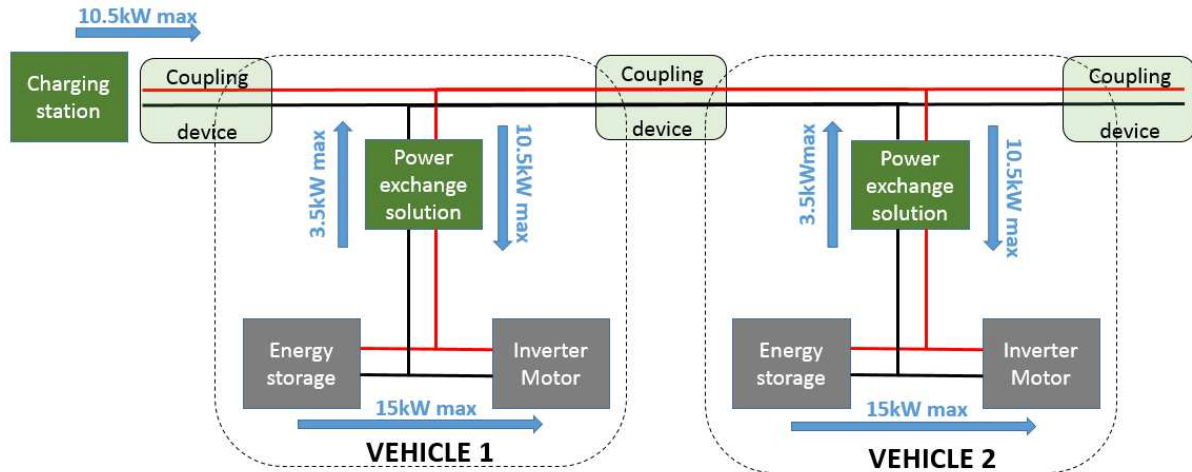

Figure 2 - main electrical architecture

The main specifications of the energy storage system and power exchange converter are:

- Li-ion chemistry: LiFePO4
- Unity cells format: 2.3Ah 26650, power cell
- Battery system composed of 12 modules 8S5P in series (320V, 3.5kWh)
- Maximum charge current : 3C \rightarrow 34,5A
- Maximum exchange current : 1C \rightarrow 11,5A

The main question we will address in this paper is:

Regarding the main criteria, balancing duration, losses and efficiency, volume and weight, cost and simplicity, behavior in case of short-circuit, what is the best power electric solution to exchange energy between LiFePO4 Li-ion batteries?

2.1 Battery model

To perform these comparisons a battery model, which includes the parameters capacity, internal resistance and voltage versus state of charge (SOC) is used:

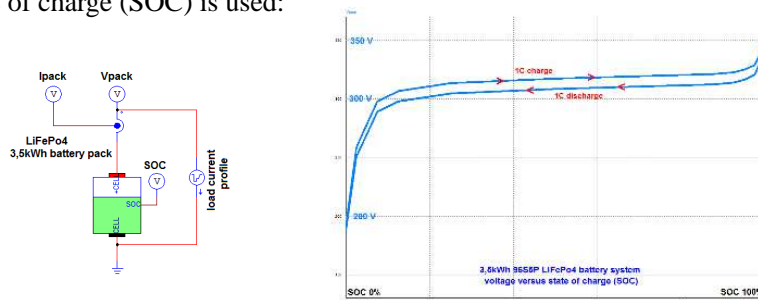

Figure 3 – Charge discharge battery cycle

2.2 Comparisons of four different power conversion solutions

In this part, after having detailed what happened in case of connection between two batteries in parallel without any adapted power electronics system, we will compare four solutions. The main objectives of these different solutions are firstly to compensate a difference of voltage between two sources and secondly to control the current flowing between these two sources.

To perform the comparisons, we use the following case of study:

- Battery 1 with an initial state of charge (SOC) of 5%
- Battery 2 with an initial state of charge (SOC) of 95%
- The balancing sequence is ended when the difference of SOC is less than 10%

2.2.1 Behavior of the system without any control of energy

Each battery system is protected against short-circuits and overloads with dedicated fuses. For example, we can use for our application a fuse OHEV040 (40A) from Littlefuse, specified with a resistance of about 2mΩ and a melting energy of 1495 A²s. The length of the cable between the two battery systems is estimated at 2 m, with thus a resistance of about also 2mΩ. The internal resistance of each battery is 192 mΩ. With all these assumptions the equivalent circuit is the following:

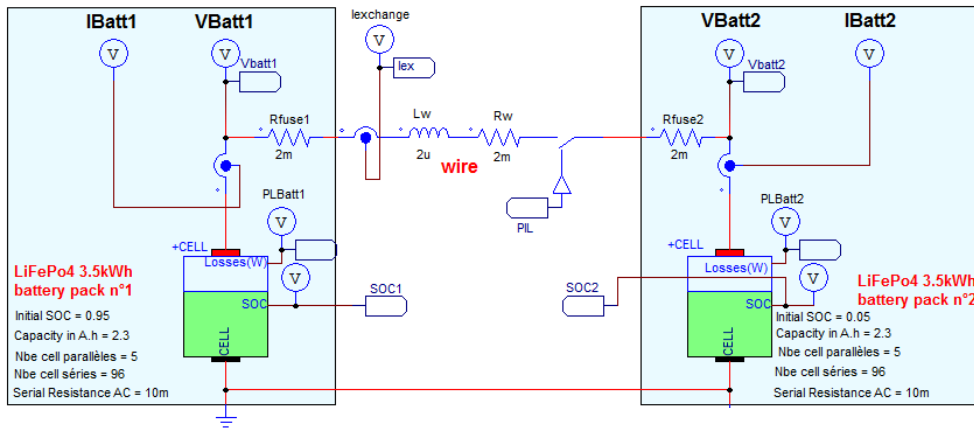

Figure 4 – reference simulations with two batteries in parallel

With initial states of charge of 95% and 5%, the starting exchange current is higher than 100A.

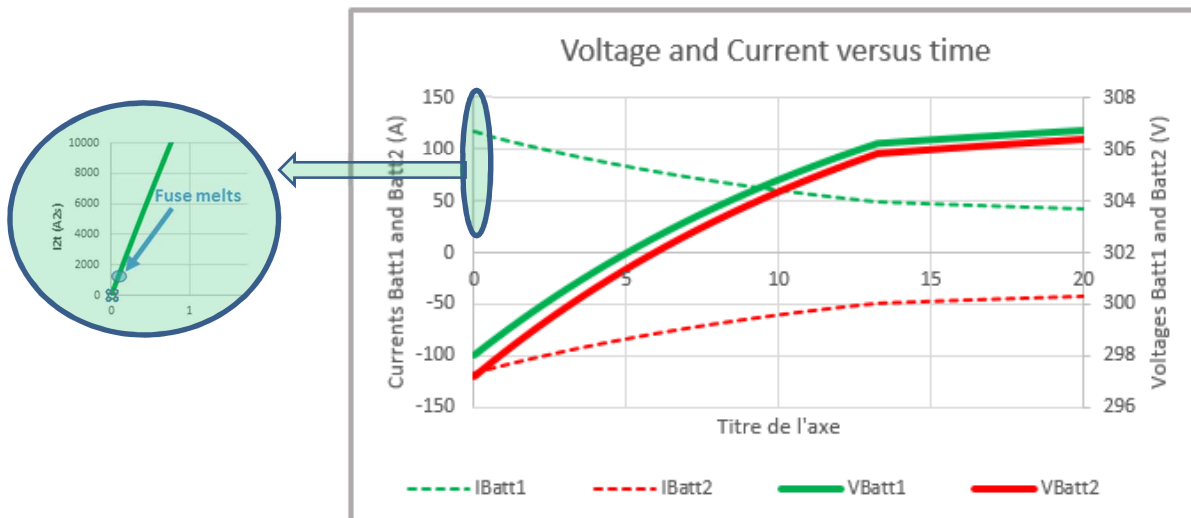

Figure 5 - waveforms without limitation device

With these simple simulations we can easily understand that the current is here only limited by the internal resistances of the two battery systems, which are much higher than the wiring resistances. Without any external control of the current, the fuse melts very quickly in less than 1s. To bear such currents, we could oversize the fuses to allow the exchange of currents. But the high current levels (up to 10C) generate thermal losses inside battery systems and has an impact on battery life time.

In this reference simulation we can calculate balancing time and energy losses:

- Balancing time : **2600 s**
- Energy exchanged : **5147kJ (1429Wh)**
- Losses inside the two battery systems : **160 kJ**
- Losses inside cabling : **1794J**

2.2.2 First control solution: full power bidirectional DC/DC boost converters

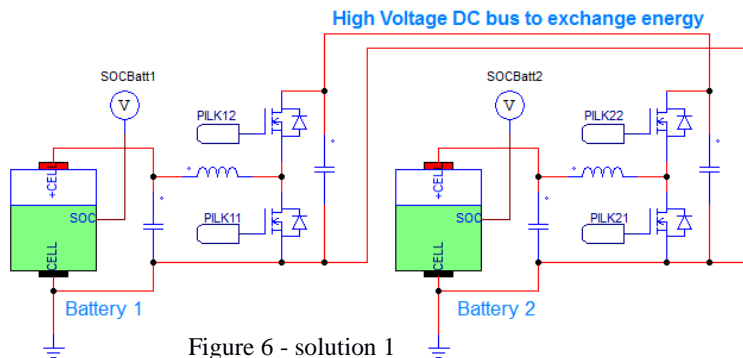

Figure 6 - solution 1

The first solution proposed to exchange energy is a solution with two bidirectional converters which can be used in boost (direct) or buck (reverse) modes. For instance, a solution to exchange energy between Battery 1 and Battery 2, if the voltage level of Battery 1 is higher than voltage level of Battery 2, is to close K12, to open K11 and to use K21, K22 in buck configuration mode.

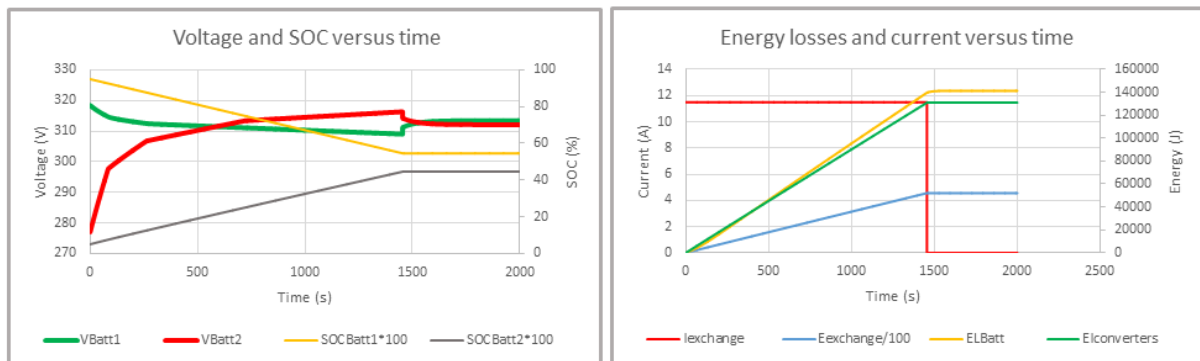

Figure 7 - waveforms solution 1

Unfortunately, the two converters can't be used to protect the system against short circuits on the high voltage bus. Because of the diodes D12 or D22 the currents flowing through the converter can't be interrupted. With an estimated efficiency of 97.5% (2% of losses in the converter and 0.5% in the switch K12), we can calculate balancing time and energy losses:

- Balancing time : **1455 s**
- Energy exchanged : **5200 kJ (1447 Wh)**
- Losses inside two batteries systems : **141 kJ**
- Losses inside converters : **131 kJ**

2.2.3 Second control solution: full power bidirectional DC/DC buck converters

In the configuration with two bidirectional buck converters, each converter could be either used either in buck mode (direct) or in boost mode (reverse). A solution to exchange energy between Battery 1 and Battery 2, if the voltage level of Batt1 is higher than voltage level of Batt2, is to close K22, open K21 and to use the switch K11, K12 in buck configuration mode.

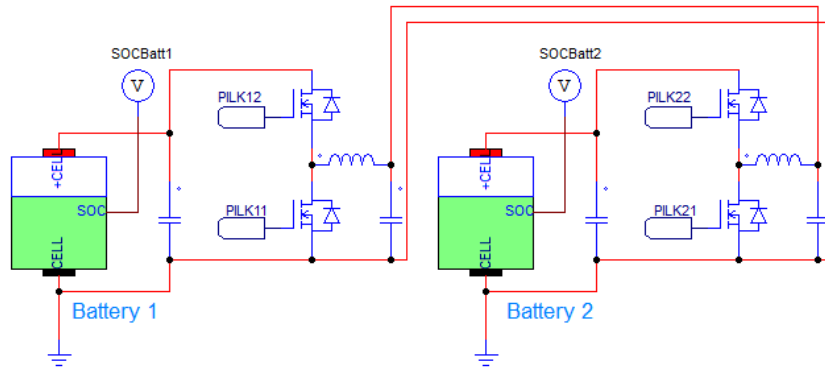

Figure 8 – solution 2

In contrast of the previous solution, the two converters can be used to protect the system against short circuits on the high voltage DC bus. With an estimated efficiency of 97,5% (2% of losses in the converter and 0,5% in the switch K12), we can calculate balancing time and energy losses, which are the same as in the previous case.

2.2.4 Third control solution: “low power” isolated bidirectional converters

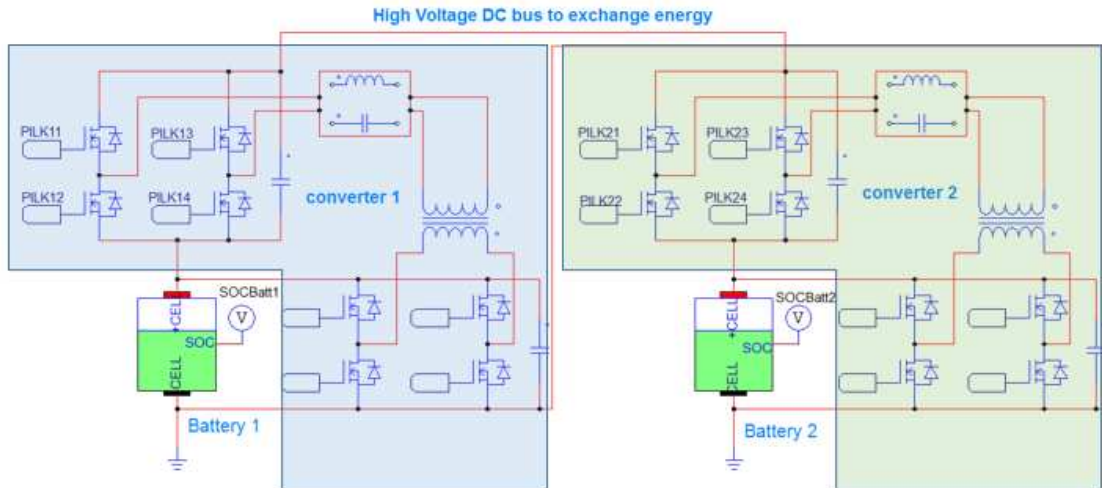

Figure 9 - solution 3

In this configuration the idea is to design a small power converter, sized only for the voltage difference between the battery packs. The power is much lower. A bidirectional isolated power converter is used. It allows a voltage conversion on each battery pack. With a correct regulation, the current exchanged between Battery 1 and Battery 2 can be easily controlled. The drawback is that this system, without any other modification, can't be protected against short circuit.

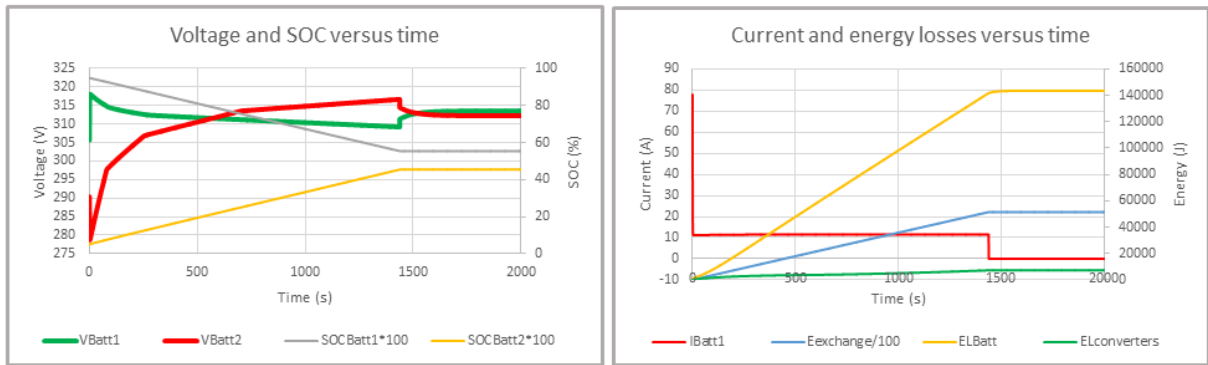

Figure 10 - waveforms solution 3

The losses inside the two converters are very low, in comparison of the energy exchanged. The main losses are located into the two batteries. At the beginning of the exchange, only the converter 2 is used to create a voltage difference and then limit the current. During this phase the switches K11, K12, K13, K14 stay closed and are used in synchronous mode to minimize the losses. At the end of this phase, when the voltage difference is too low to obtain the right level of current, the converter 1 is used to create a higher voltage difference. It allows to continue to push the current in Battery 2.

The peak power transmitted by converters is about 500W, whereas the mean power is less than 100W (see figure 11)

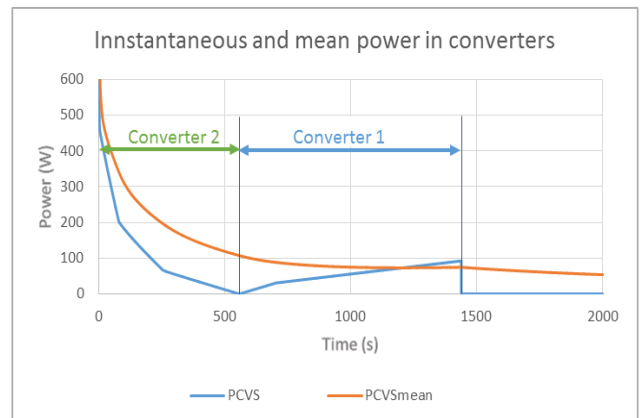

Figure 11 - power in converters

With an estimated efficiency of about 95% (5% of losses in the converters and 10mΩ to take into account of the closed switches in synchronous modes), we can calculate balancing time and energy losses:

- Balancing time : **1455 s**
- Energy exchanged : **5150 kJ (1430 Wh)**
- Losses inside two batteries systems : **143 kJ**
- Losses inside converters : **7,2 kJ**

We can remark that the losses inside converters are very low in comparison with the previous solutions. This can be explained by the optimized power of the solution and by the very low resistance of power MOSFET in synchronous mode.

2.2.5 Fourth control solution: “low power” regulated modules

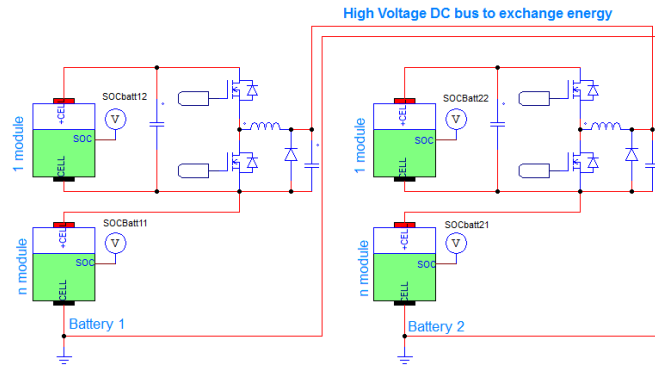

Figure 12 - solution 4

In this configuration each battery is divided into two parts. A first part with n modules in series (n=11 in our case) and a second one with only one module associated with one converter. Like in solution 3, converters are sized to compensate only the differences of voltage between batteries and not for the all voltages. But the main problem of this solution is the need of a specific module with also a specific software algorithm for SOC calculations and balancing. This solution will not be more detailed in this paper.

2.2.6 Fifth control solution: linear regulators

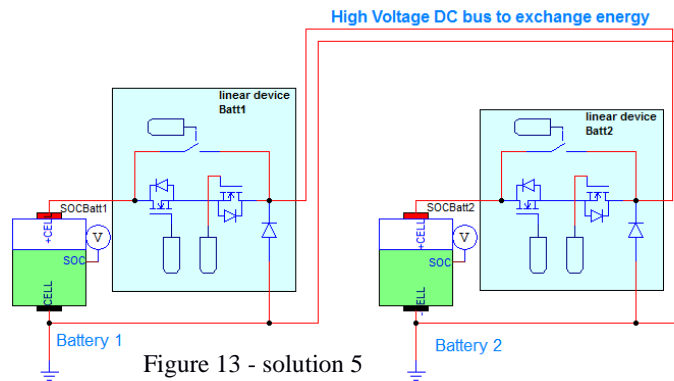

Figure 13 - solution 5

In this configuration, we use the flat curve (voltage versus SOC) of Lithium-ion Iron Phosphate batteries and we try to evaluate if there is an interest to use simple bidirectional transistors in linear mode to limit the current. A relay is added in parallel to optimize the serial resistance when the switch is completely closed.

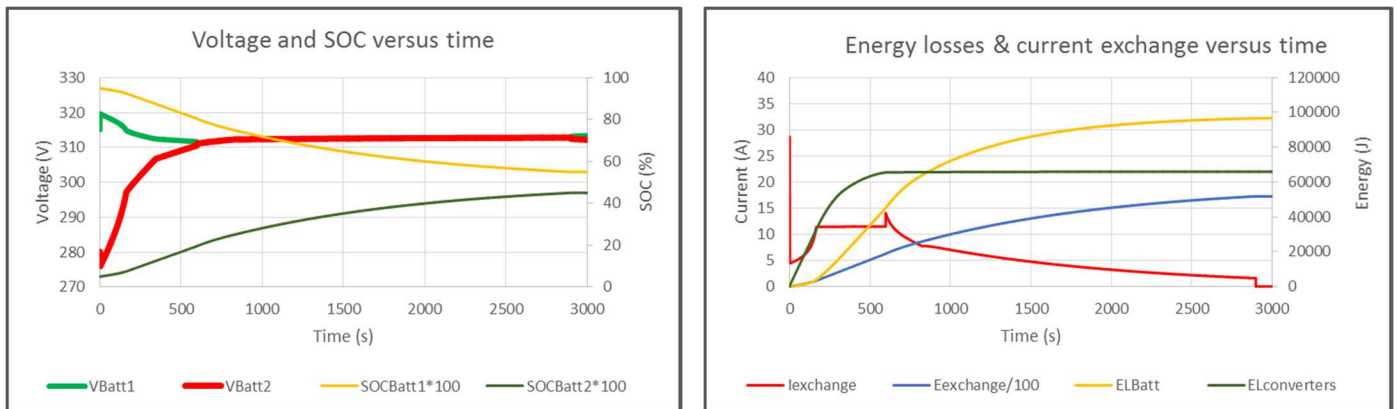

Figure 14 - Simulation of current exchange with solution 5

In this last configuration we can calculate balancing time and energy losses:

- Balancing time : **2900 s**
- Energy exchanged: **5177kJ (1438Wh)**
- Losses inside two battery systems : **96 kJ**
- Losses inside converters : **66kJ**

The main drawback of this solution is the balancing time which is higher than with converters solutions. That can be explained, by the impossibility to create an artificial voltage difference between battery 1 and battery 2, to accelerate the energy exchange. However this solution has many advantages. It seems to be the simplest one, it presents a high efficiency and it allows to limit the current in case of short circuit. The sizing of limitation device must be precisely studied, especially regarding transient thermal considerations.

2.3 Results of the comparisons

	Solution 0 Reference simulation without any current limitation	Solution 1 High power boost converters	Solution 2 High power boost converters	Solution 3 Low power isolated bidirectional converters	Solution 4 Low power regulated module	Solution 5 "Linear regulator"
Max/mean power of balancing device (W)	No limitation	3974 / 3532	3974 / 3532	500 / 74	NE(*)	10000 / 1785
Losses in battery systems (kJ)	160	141	141	143	NE(*)	96
Losses in balancing devices (kJ)	No device	131	131	7,3	NE(*)	66
Energy exchange (kJ)	5147	5200	5200	5150	NE(*)	5177
Mean estimated efficiency (%)	NE	97,5	97,5	99,8 %	NE(*)	98.7
Balancing duration (s)	2600	1455	1455	1438	NE(*)	2900
Short circuit limitation	No	No	Yes	No	No	Yes
Complexity	NE(*)	++	++	+++	+++	+
Volume, weight, cost	NE(*)	+++	+++	+	++	+
Specific module	No	No	No	No	yes	No

Figure 15 - comparison table between solutions

*NE=non estimated

The two preferred solutions are the solutions 3 and 5, which seems much more efficient than the others. The solution 3 will be implemented in the next months. A two stages topology with a first isolated fixed ratio converter and a second bidirectional buck-boost converter will be evaluated.

3 Impact of battery technology and usage on the preferred solution

The battery technology and the usage have an impact on the preferred solution because the sizing of the balancing device is directly linked with the following criteria:

- Specification of balancing time (usage)
- Usage of the battery (micro-cycles or cycles) which impact the voltage variation
- Battery technology which impacts directly the curve voltage in function of SOC and thus the maximum power of the balancing device

4 Conclusion

In this paper, we compared different solutions to exchange energy between high voltage iron phosphate Lithium-ion (LiFePO₄) battery packs. Two of them seem very interesting for our application (see table figure 15). The solution 3 “Low power isolated bidirectional converter” presents a very high efficiency and is certainly the most compact one. The only important drawback is its impossibility to protect the system against short circuits by limiting the current. The solution 5 “Linear regulator” is certainly the simplest one, and presents an efficiency higher than standard solutions with buck or boost converters for iron phosphate Lithium-ion batteries. It allows to protect the system against short circuits. However the transient thermal aspects must be studied carefully in order to obtain a performant solution.

References

- [1] M. Desbois-Renaudin, D. Chatroux, S. Carcouet, “DC voltage source including electrochemical cells having an adaptive voltage level”, Brevet n° WO2013072362
- [2] David Bourner, Maurizio Salato VICOR „Levearing Bus Converters in Regulated DC-DC Applications – Comparative Study vs Yeaman Topology and Factorized Power Architecture“

Authors



M. Laurent Garnier is a power electronic expert. After eighteen years in industry in R&D for specific power converters, he joined the CEA in 2010. He is working since seven years in the department “Electricity and Hydrogen for Transport” on batteries management systems, fuel cell systems and power electronics devices like chargers, DC/DC converters or inverters. During this period he has participated to 13 patents.