

# evs 30

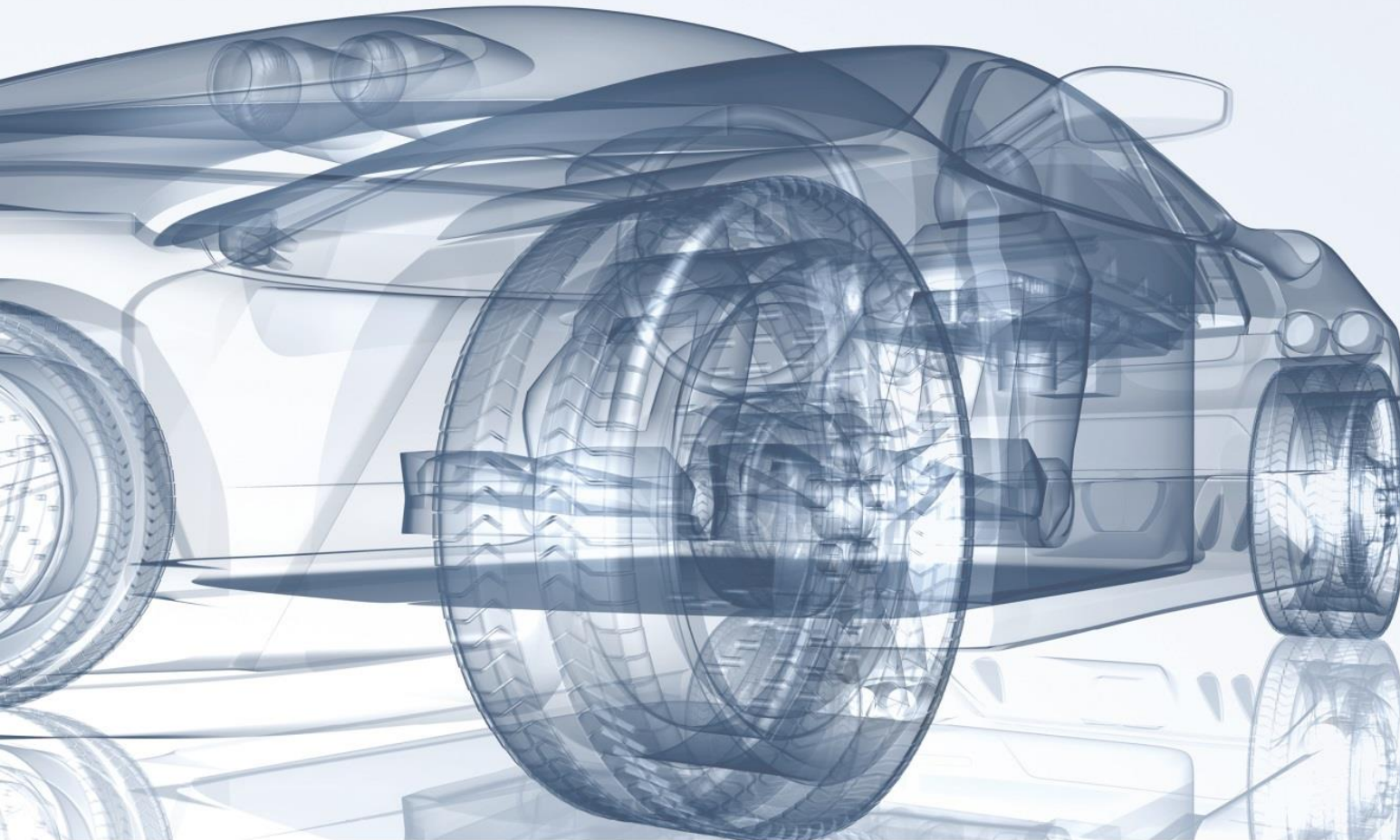

The 30th International  
Electric Vehicle  
Symposium & Exhibition

**October 9–11, 2017**  
Messe Stuttgart, Germany

[www.evs30.org](http://www.evs30.org)

Sponsored by

DAIMLER



**BOSCH**  
Invented for life

GRUPE RENAULT

MAHLE

EnBW



PORSCHE

swarco



SOLARIS

## PUBLIC TRANSPORT OF TOMORROW >

Zero emissions vehicles including electric buses and buses with fuel cell range extenders

Michał Sierszyński, Bartłomiej Walczak, Adam Piotrowski, Michał Pikuła

[www.solarisbus.com](http://www.solarisbus.com)

Marco - Polo - Terrassen  
Zone 000  
111 HafenCity (Baakenhöft)  
602 Zollvereinsstraße - Kraftwerk Tiefstack  
B Maritime - Linie  
C City - Linie  
D Classic - Linie  
Die Hanse - Stadtrundfahrt  
A Die Roten Doppeldecker





**Company**

## Solaris Bus & Coach

- **Independent manufacturer** of buses, trolleybuses and trams
- **100% owned** by **Olszewski** founding family
- **€396 million** annual turnover (2016)
- **2500 employees**
- **Over 1400** vehicles **production in this year**
- **Over 15 000** vehicles sold since start of production
- International presence – **32 countries**

### **BOLECHOWO**

Headquarters  
Bus assembly

### **ŚRODA WIELKOPOLSKA**

Bus welding plant

### **JASIN**

Solaris Logistics Center

### **POZNAŃ**

Tram assembly

### **ŚRODA WIELKOPOLSKA**

Tram welding plant



## Alternative powertrains

### Alternative solutions for diesel buses

- › Energy need to be provide not only for drive train but also for on-board systems and heating / air conditioning systems which are one of the most significant factors, which determines single-charge range
- › Diesel bus drive a minimum of 350 km on one refueling even in the most difficult winter conditions with fully operational heating, so it is not easy to replace them with other solution



Hybrid bus

Solaris Urbino Hybrid



Electric bus

Solaris Urbino electric



Trolleybus

Solaris Trollino



CNG bus

Solaris Urbino CNG





**COMMON  
DIRECTION >**

**E-mobility**

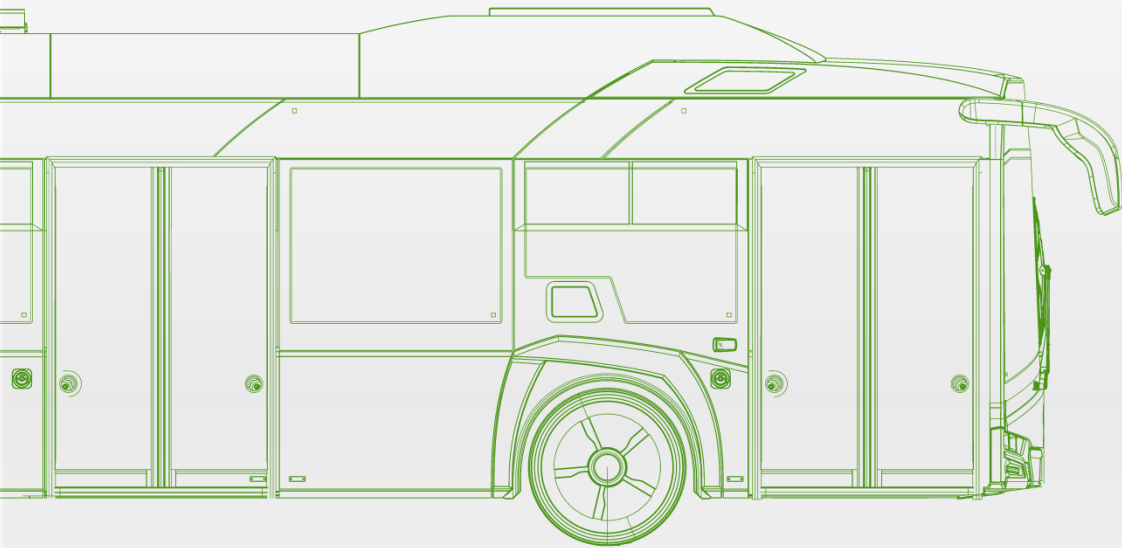

**2000** buses with **electric powertrains**  
 (including buses in production)



The map shows zero-emission buses as well as trolleybuses with batteries allowing the vehicles the autonomous drive



**COMMON  
DIRECTION >**



The influence on society

the total Solaris Research & Development expenditure over the years 2012-2015

It is almost twice the amount of **annual budget of Polish Academy of Sciences**



**BUS  
OF THE YEAR  
2017**

**New Solaris Urbino 12 electric  
Bus of the Year 2017**



**Market development**

## Prognosed electric bus market size yearly

- > Based on research and prognoses by UITP, VDV, SCI Verkehr with adjustment according to Solaris market expertise

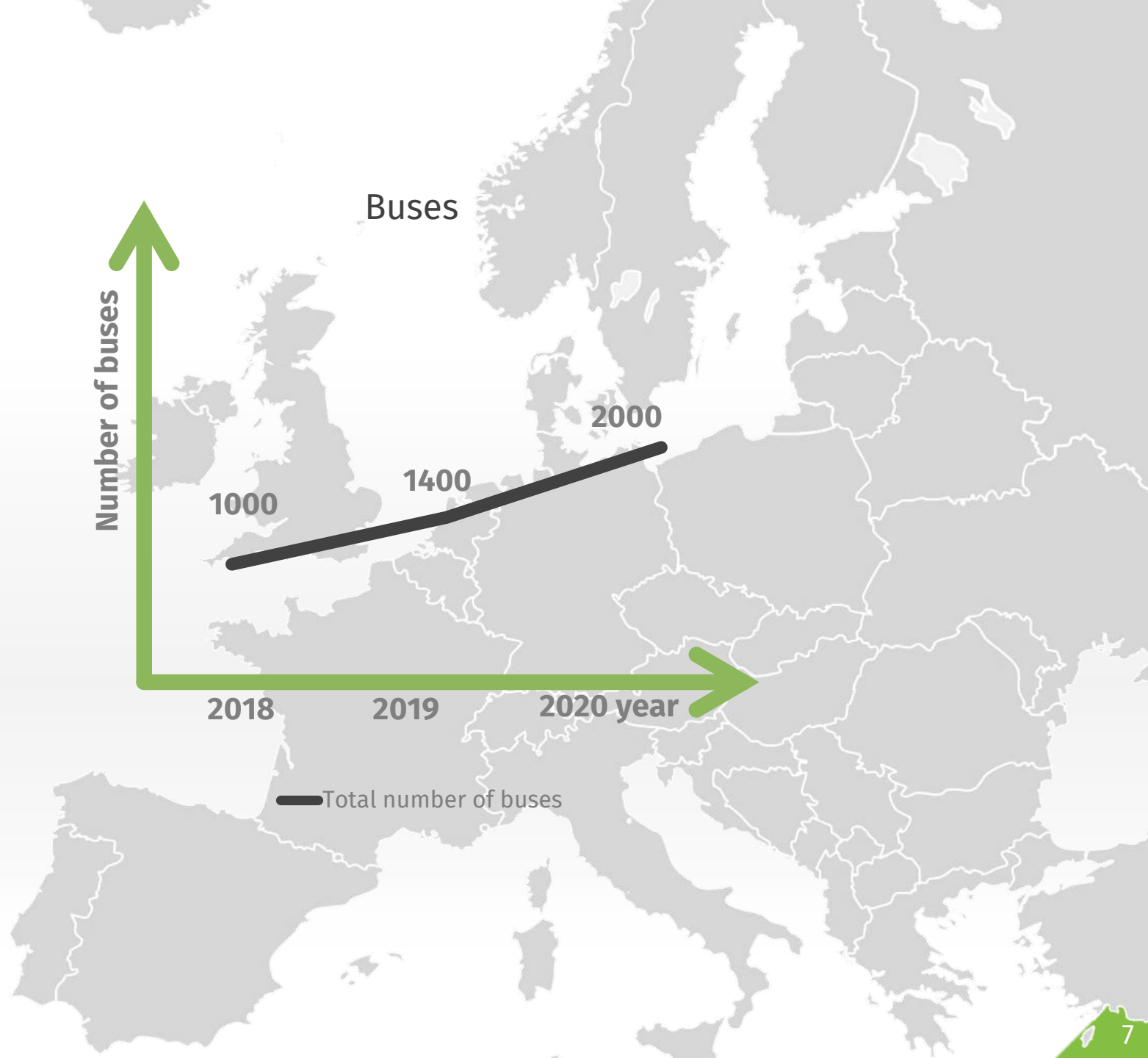
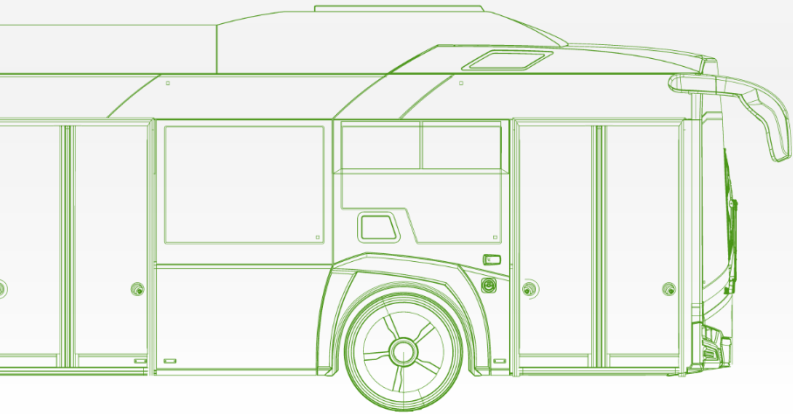



## The influence on environment

76% 

reduction of vibration in the driver's seat on an electric bus, compared to a bus with a petrol or diesel engine

28% 

lower noise level in the back of an electric bus compared to a bus with a combustion engine

16% 

lower noise level generated by an electric bus when moving away from a stop compared to a bus with a combustion engine

Not only emissions of harmful substances to the atmosphere at the place of use of the vehicle is an important environmental aspect. It is also important to **take care of the environment by reducing noise and vibration caused by public transport vehicles.**



# The influence on environment

Polish streets



Diesel buses



x 11 376



electric buses

Total average reduction of  
socio-economic costs of  
**noise** in annual terms\*\*

**9.38\***  
mln EUR

Total average reduction of  
socio-economic costs of  
**noise**, over a period of 10  
years\*\*

**93.8\***  
mln EUR

\* 1 EUR = 4.2 PLN

\*\* simulation for 11 376 city buses in Poland. For this purpose, the authors assumed on overall number of city buses (as 31<sup>st</sup> December 2015) less those running on alternative fuel. Data is based on the report: Transport. Activity results in 2015, prepared by the Central Statistical Office (GUS).

Costs are more important than brand and look – what do Poles choose to be guided by if it comes to buying low-emission car?

**Technical requirements**

## Technical requirements for zero emission vehicles

- > PTO's, whose fleets are dominated by Diesel buses, are frequently asking bus manufacturers about nearly the same features which applies to passenger cars.

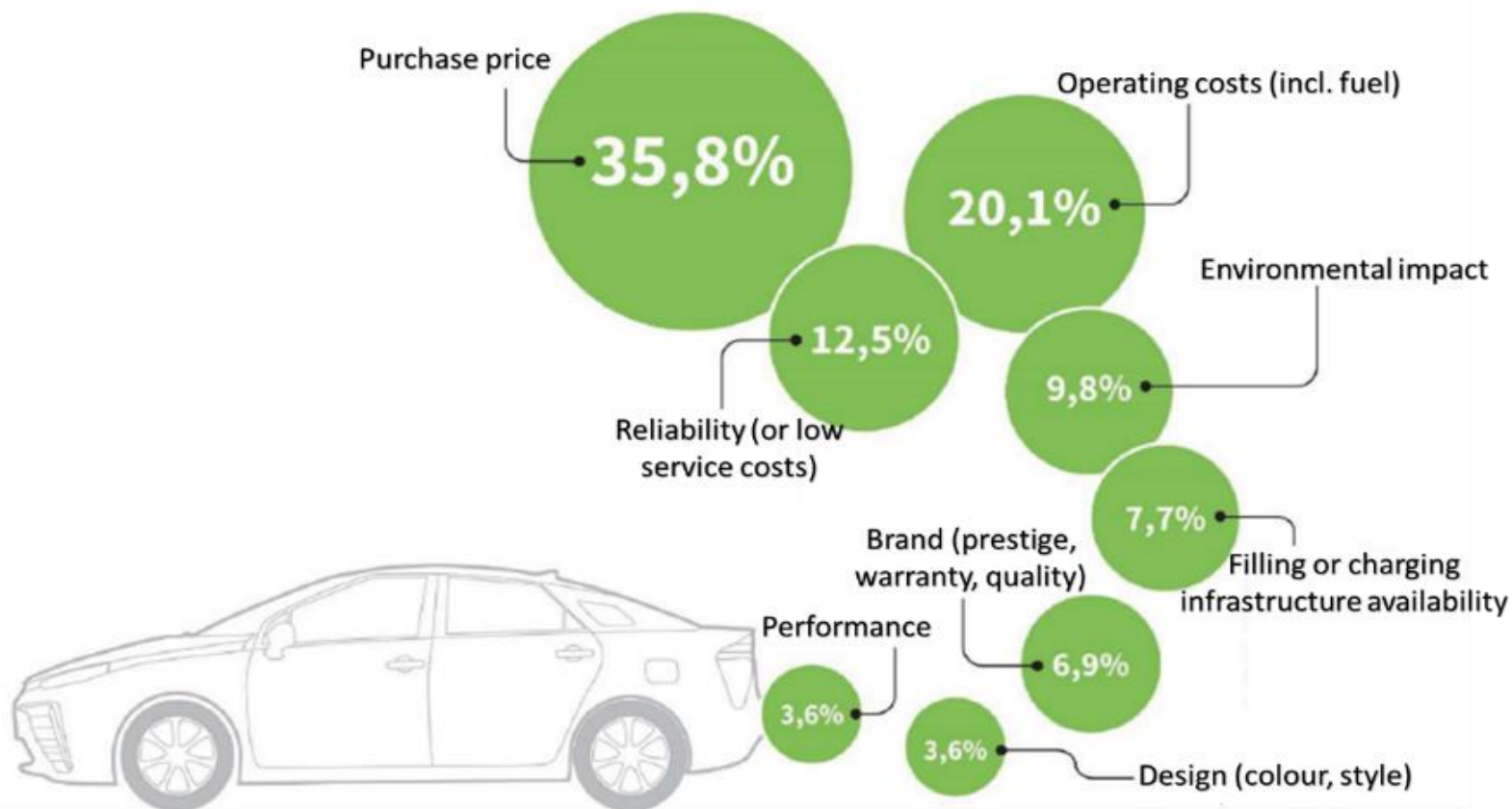

Survey by SW Research for ORPA.pl, June 2015



➤ **By mid-century, GHG emissions** from transport will need to be **at least 60% lower** than in 1990 and be firmly on the path towards **zero concerning both GHG and pollutant emissions** in order to meet the EU's emissions targets.

Source: A European Strategy for low-emission mobility



## ENERGY CONSUMPTION of different bus components



### Alternative solutions for diesel buses

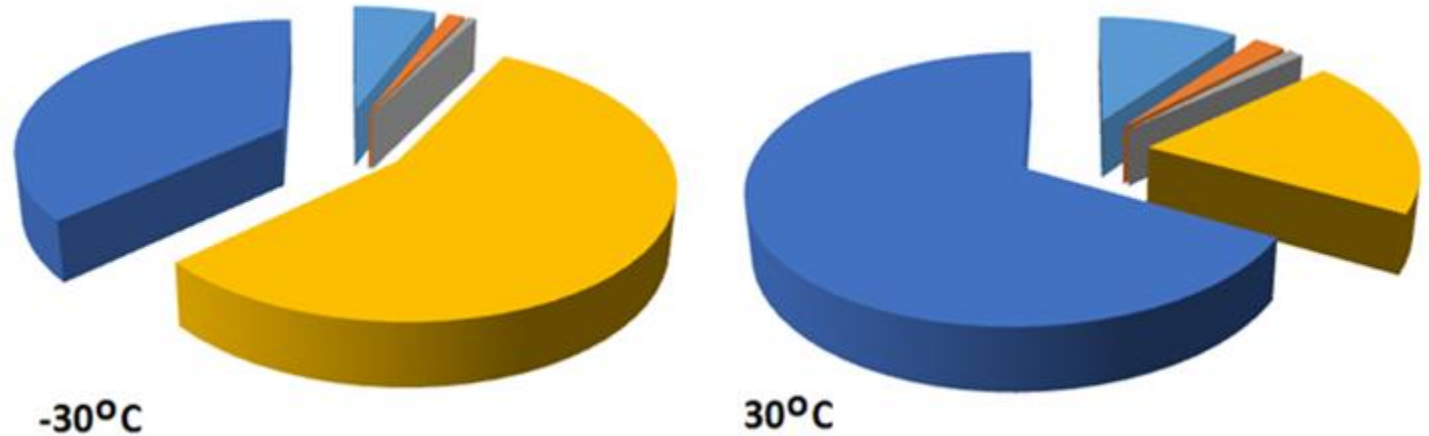

- 24V installation (without HVAC LV) – average power
- Air compressor – average power
- Power steering – average power
- HVAC(HV,LV) – available power
- Drivetrain – average power

Heating, Ventilation, Air Conditioning, Low Voltage, High Voltage

- > The impact of HVAC system is higher if the commercial speed is lower and operating temperature range is wider
- > Some operators, in favour to extend single-charge range, chose to use Diesel heating, however that bus is no longer a zero-emission bus at the area of operation

## Alternative solutions for diesel buses

Impact of HVAC on bus energy consumption - example

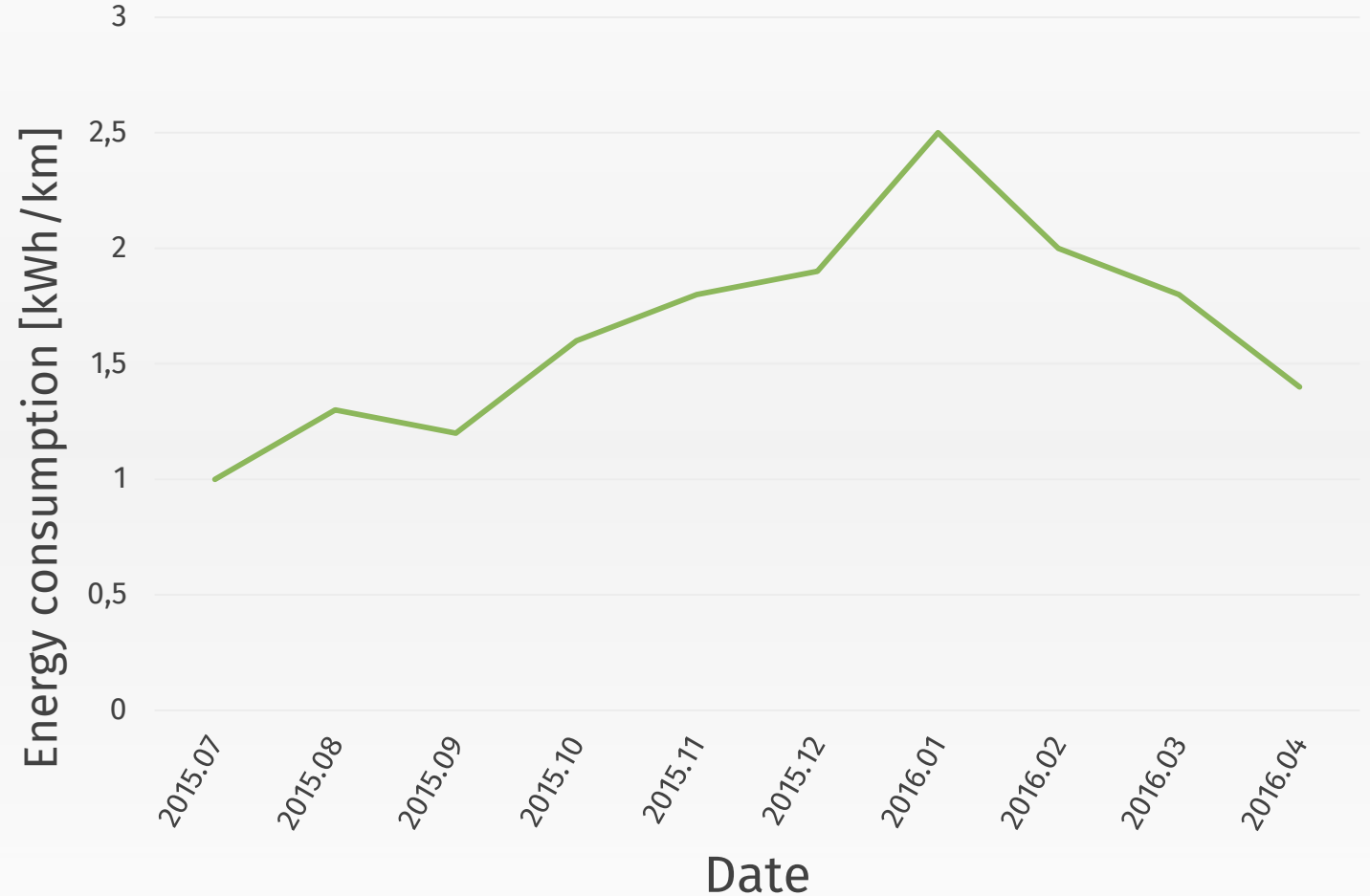

> Influence of HVAC system energy consumption on bus single charge range - an example based on SORT 2 conditions and HVAC for 22°C interior temperature

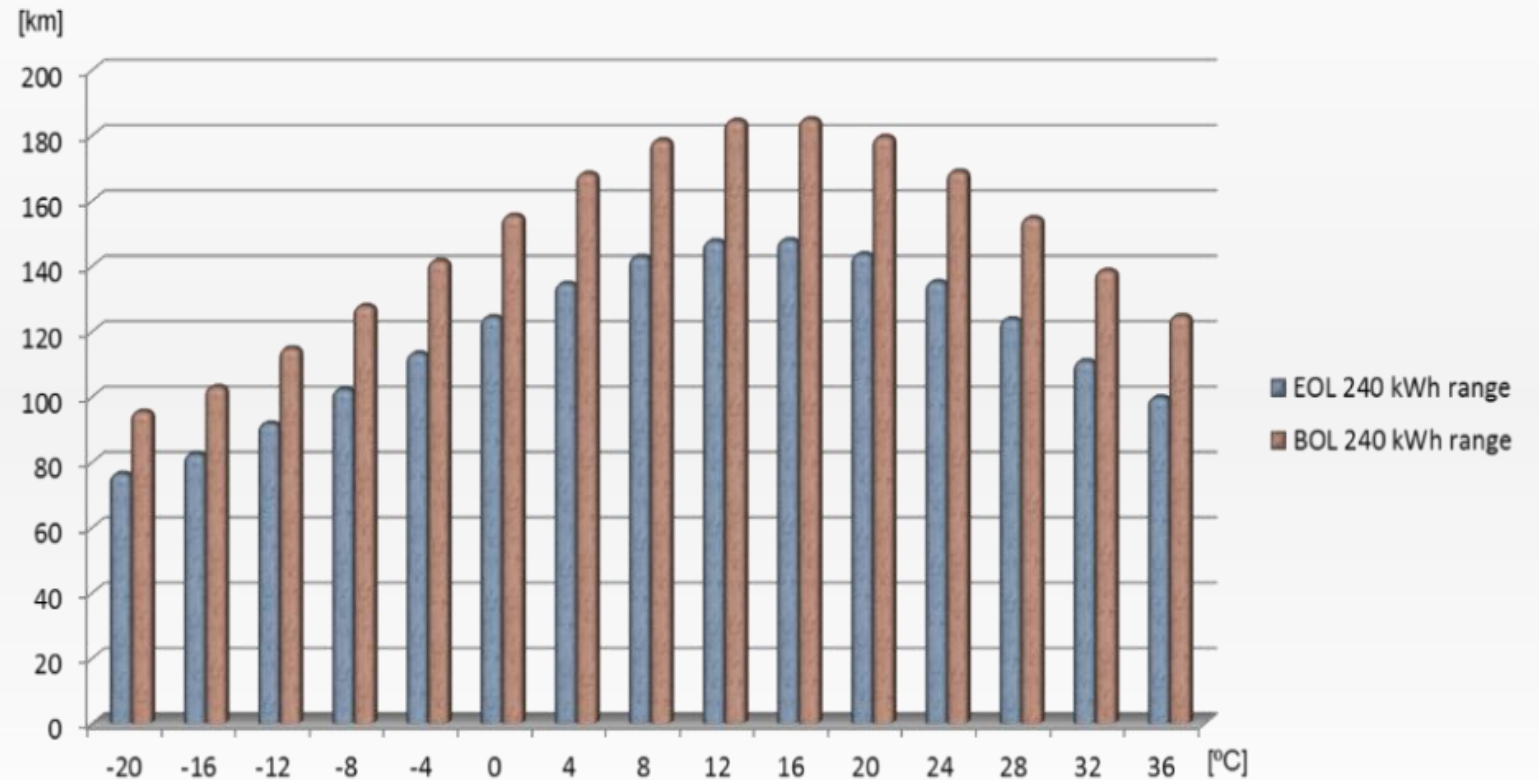



**When electric buses could be charged?**

**Overnight  
charged buses**

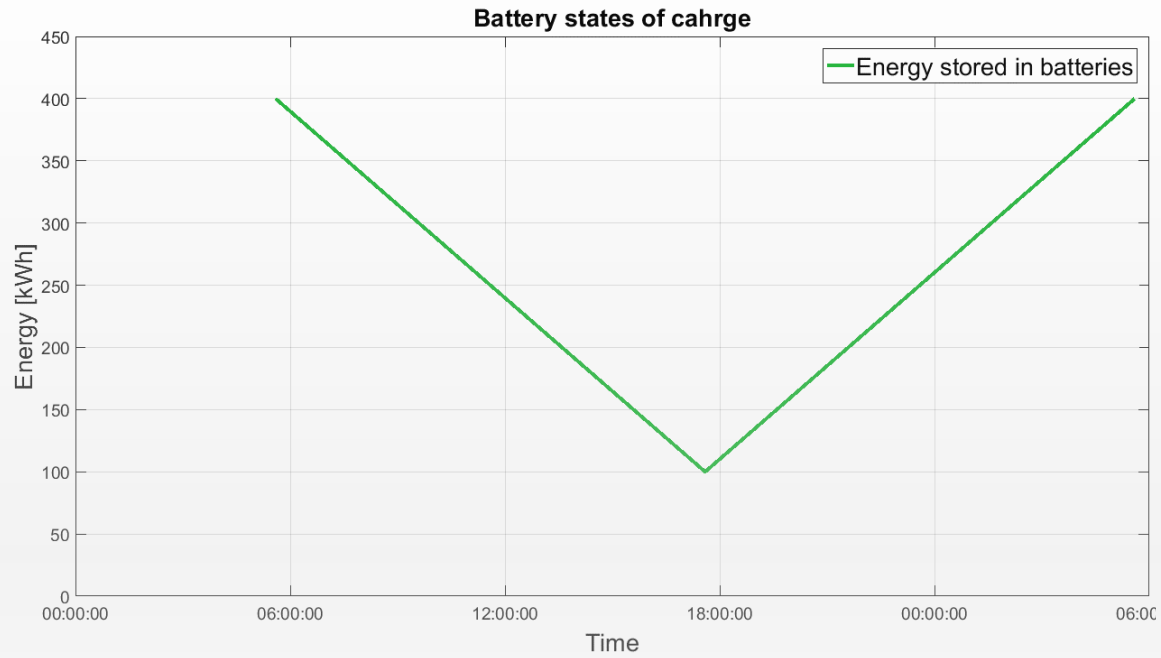

**Opportunity  
charged buses**

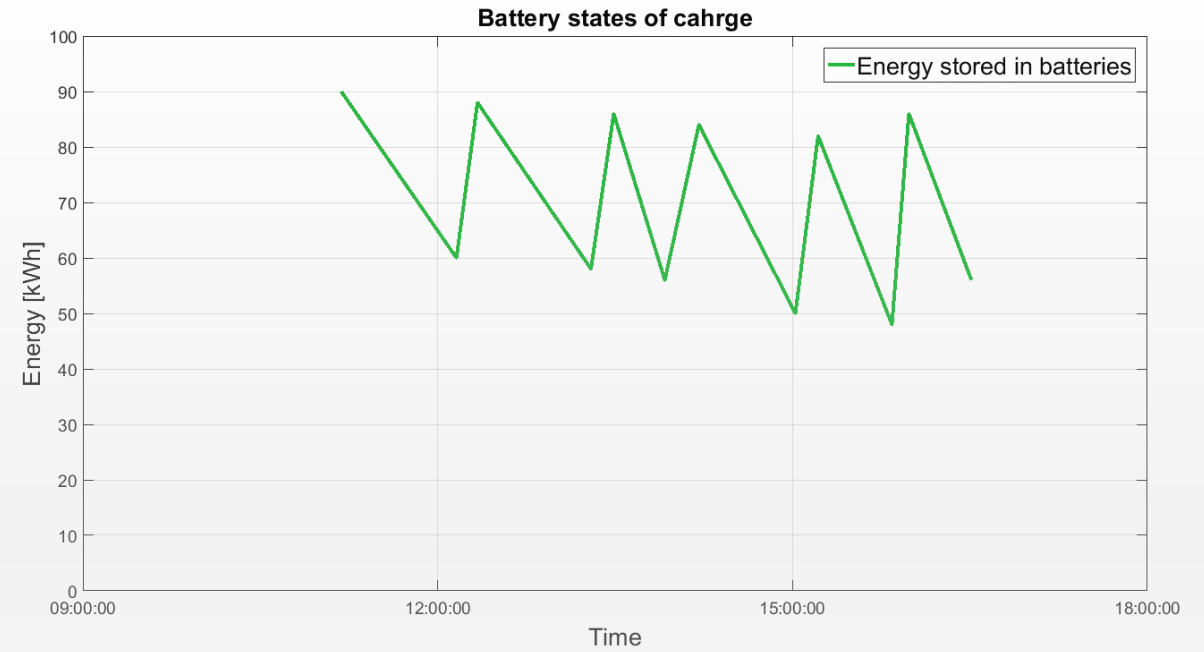



**How electric buses could be charged?**

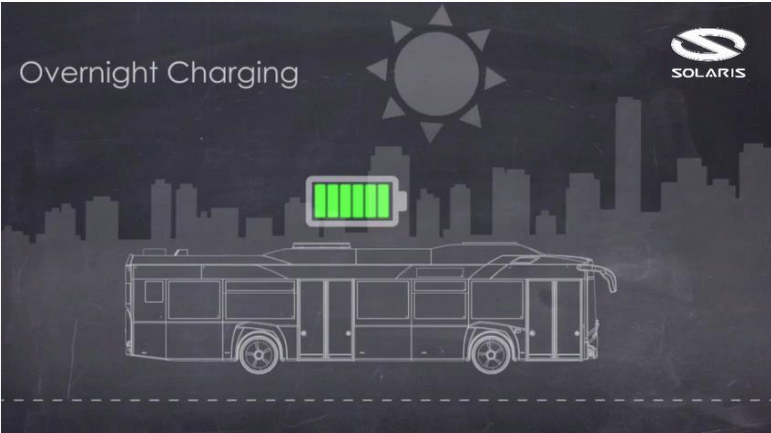

**PLUG-IN**

16 ÷ 120 kW CCS

Requires handling

**PANTOGRAPH // INDUCTION**

up to 450 kW // 200 kW

Automatic operation

**HYDROGEN // PLUG-IN**

16 ÷ 120 kW CCS

Requires handling



Charging solutions

Plug-in >



- > 16 ÷ 120 kW CCS
- > Manual operation
- > Low costs
- > Contact charging

Pantograph >



- > up to 450 kW
- > Automatic operation
- > Relatively low costs
- > Contact charging

Induction >



- > 200 kW
- > Automatic operation
- > High costs
- > Contactless charging

Fuel cell range extender >



- > Batteries are being recharged using hydrogen fuel cell range extender while driving
- > The electricity is generated by fuel cell from hydrogen



**Standardisation** of charging infrastructure will facilitate mass **deployment of electric buses** in European cities

## Opportunity charged buses

- > High Power batteries are best choice for operators, who are covering high mileages every day but **the single trip is relatively small**
- > Fast charging allows them to fill consumed energy in very short time period, **even less than 7 minutes** regardless the weather conditions

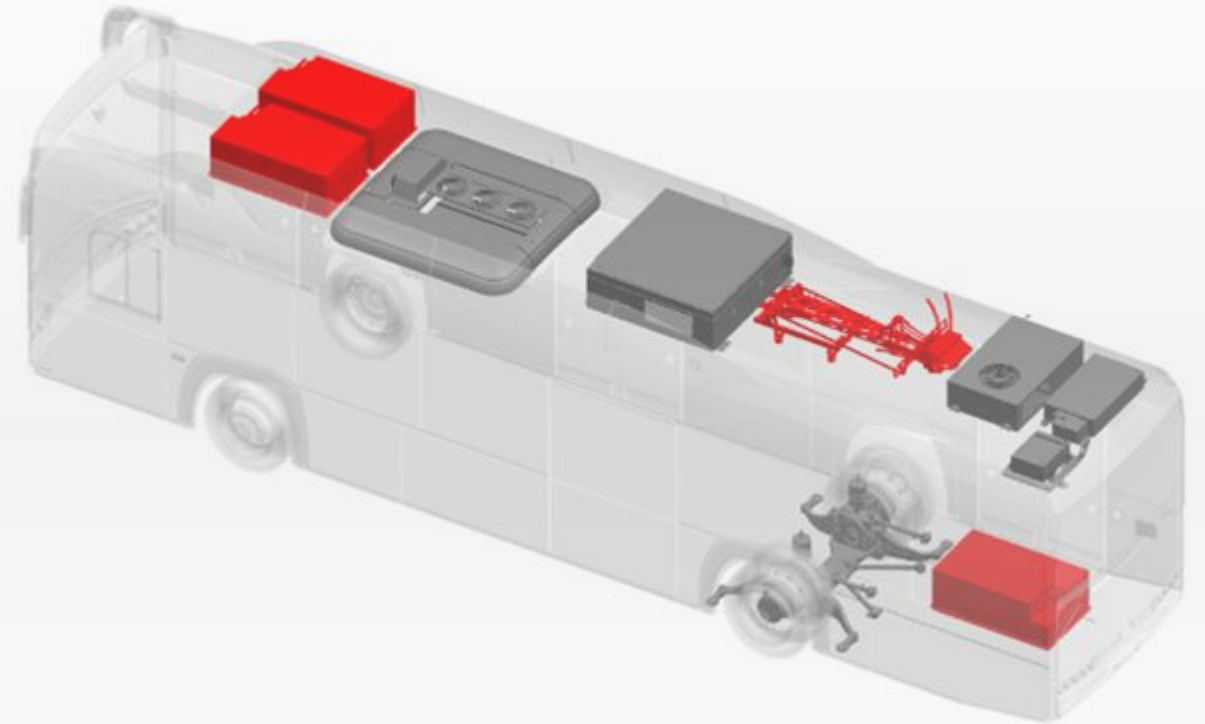

## Overnight charged buses

---

- > Currently buses with big batteries are **mostly recommended for peak operation** (rush hours) or to operate at suburban lines.
- > Rush hours are one of most **demanding challenges** for electric bus operators. Usually they occur **two times per day**: in the morning and in the late afternoon.

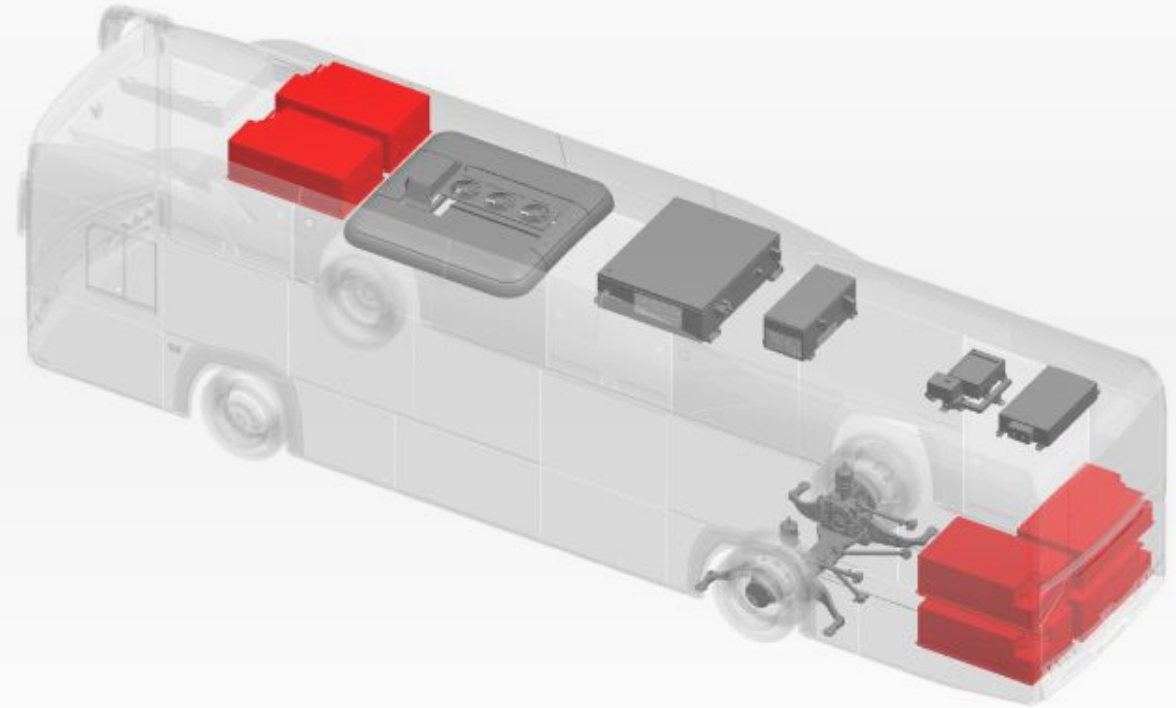

## Electric buses with fuel cell range extender

- > Size of batteries is usually **smaller** than in opportunity charged buses but there are additional elements such as fuel cell stack, auxiliary fuel cell devices and hydrogen storage system.
- > Hydrogen can significantly extend the range **to even 400 km or more** on single fueling
- > This type of bus connects advantages of fuel cell and batteries.
- > During normal drive fuel cell covers power demand of drivetrain, batteries cover peak power demands and **absorb energy form regenerative braking.**

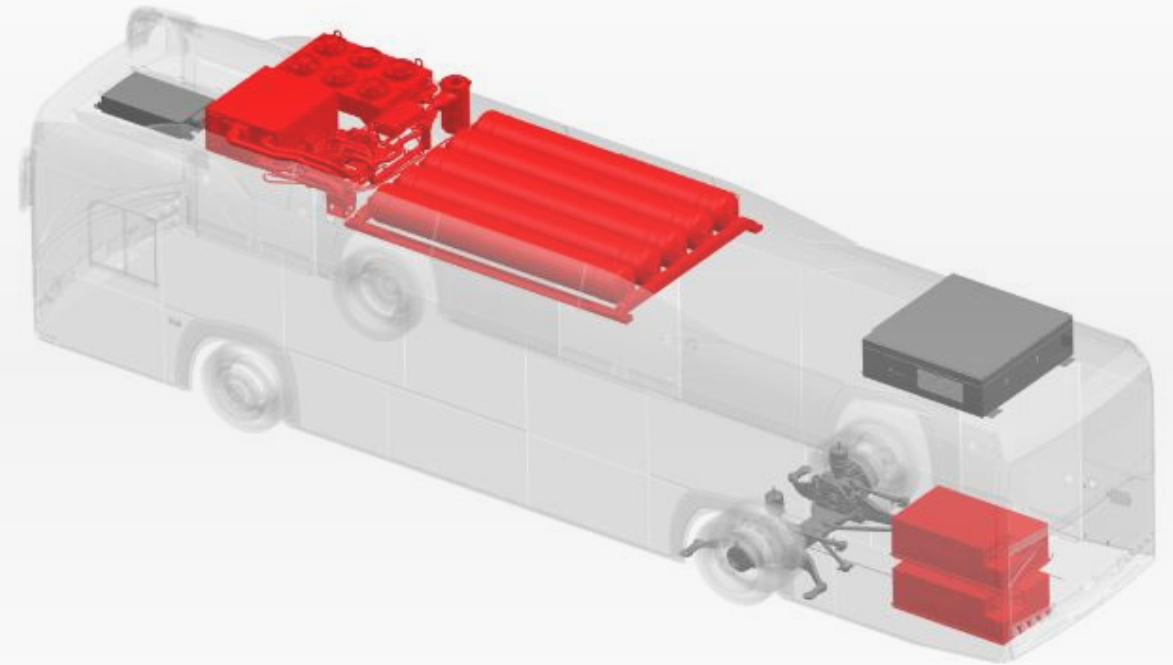



SOLARIS

## COMPARASION of diesel, hydrogen and electric >

[www.solarisbus.com](http://www.solarisbus.com)

**Diesel buses >**



- > Standard diesel bus
- > Possible energy recovery from braking
- > 15 minutes (refuel)
- > Filling stations widely available

**Hydrogen buses >**



- > Batteries are being recharged using hydrogen fuel cell range extender while driving
- > The electricity is generated by fuel cell from hydrogen
- > Lithium-ion batteries
- > 15 minutes (Hydrogen refueling)
- > 1-3 hours (batteries)
- > ~100 stations in Europe

**Electric buses >**



- > 16 – 120 kW CCS, available pantograph up to 450 kW
- > Bus of the Year 2017
- > Lithium-ion batteries
- > 1-6 hours (batteries)
- > Requires dedicated infrastructure at the depot and (optionally in the cities)



**Comparison of diesel, hydrogen and electric buses**

Drivetrain components' mass comparison [%]

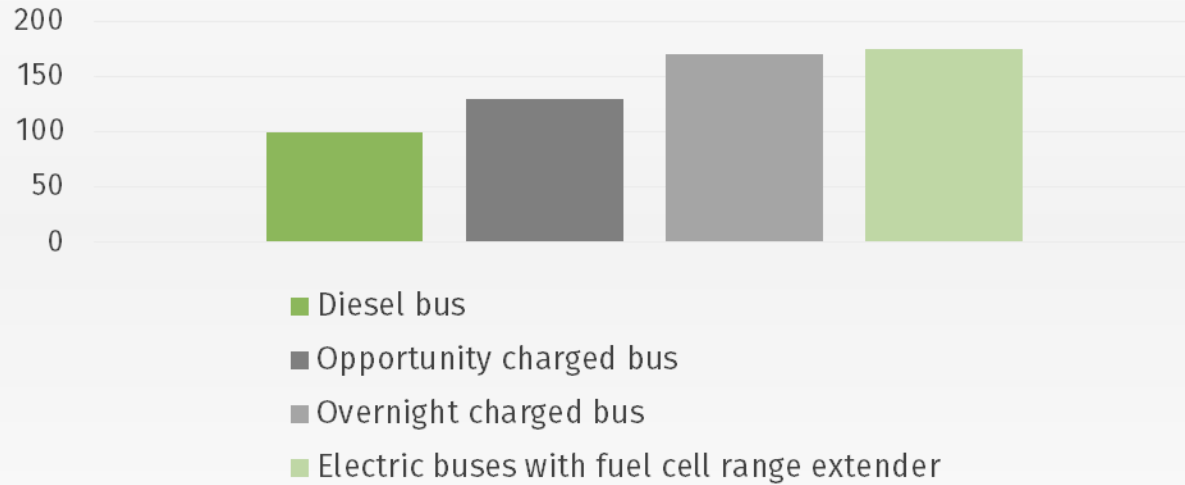

Single charge/ filling comparison

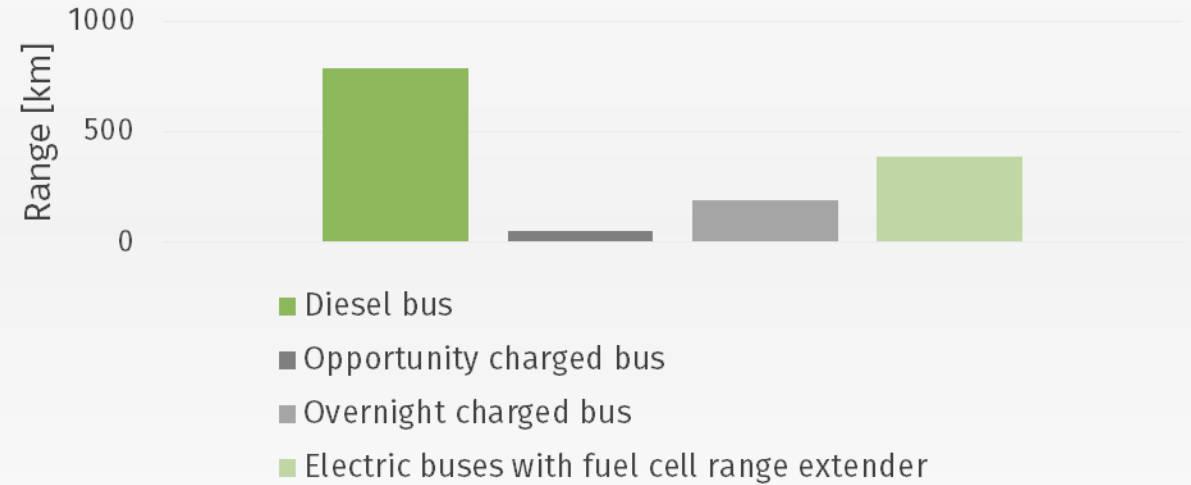

Price comparison of buses in 2017

Estimated purchase price comparison of buses [%]

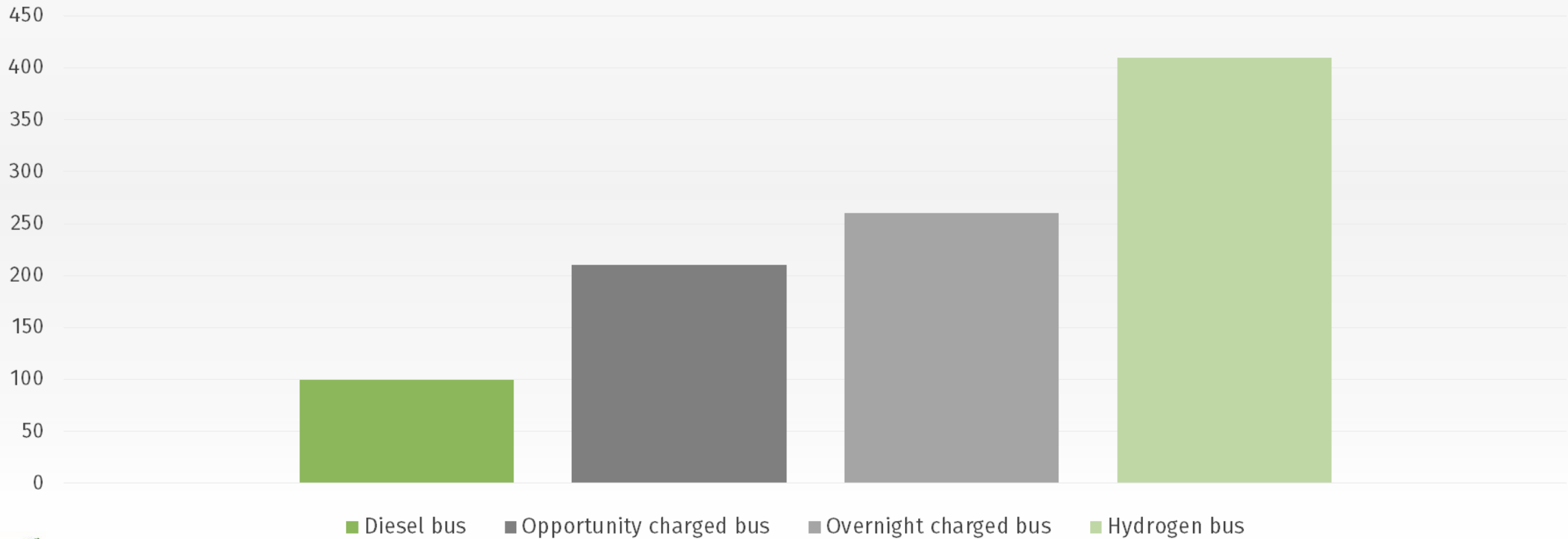

**Comparison of costs of Diesel bus and electric buses**

**DIESEL BUS**

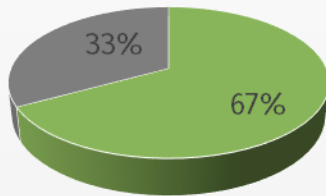

- cost of other bus elements
- estimated cost of powertrain (inc. drive axle)

**OPPORTUNITY CHARGED BUS**

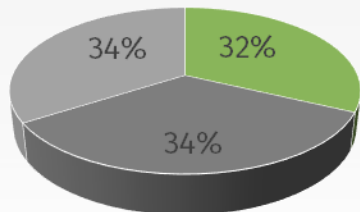

- percentage cost of batteries
- estimated cost of powertrain (inc. drive axle)
- cost of other bus elements

**OVERNIGHT CHARGED BUS**

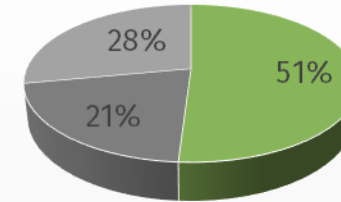

- percentage cost of batteries
- estimated cost of powertrain (inc. drive axle)
- cost of other bus elements

**HYDROGEN BUS**

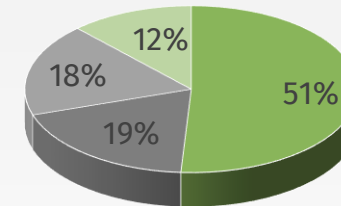

- percentage cost of hydrogen equipment (FC, storage system, auxiliaries)
- estimated cost of powertrain (inc. driven axle)
- cost of other bus elements
- percentage cost of batteries



Purchasing price standard bus ['000 EUR]

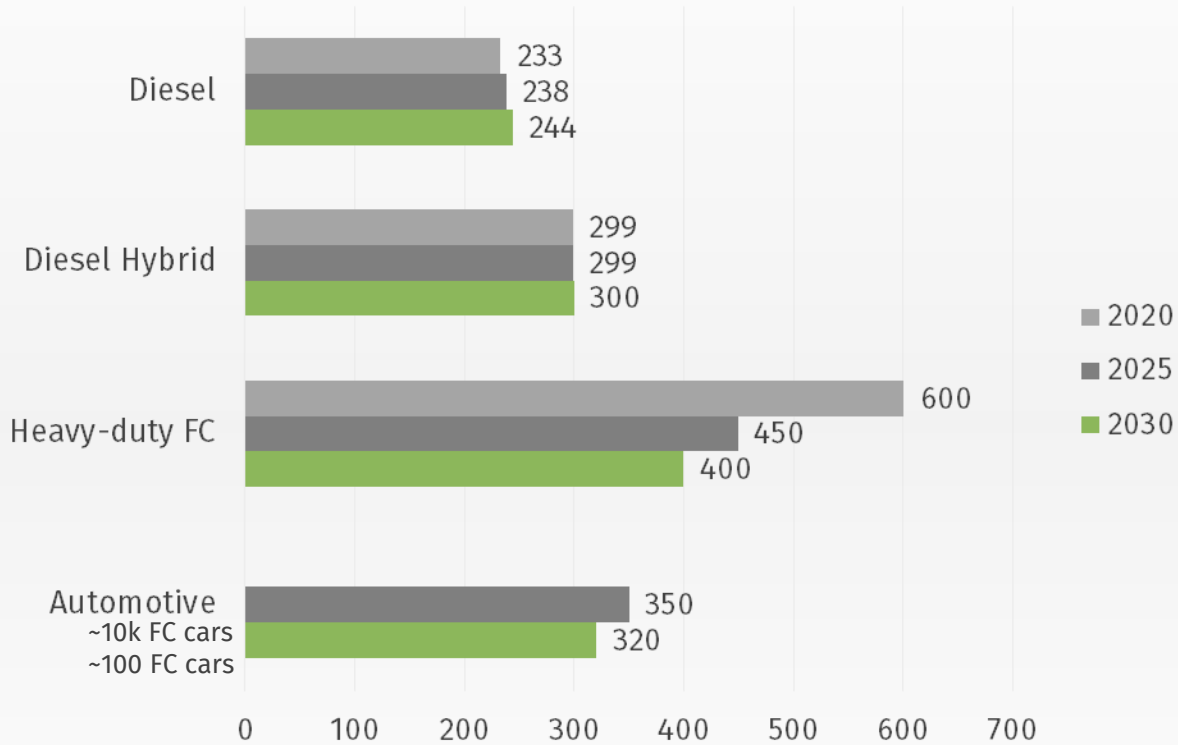

TCO standard bus [EUR/ km]

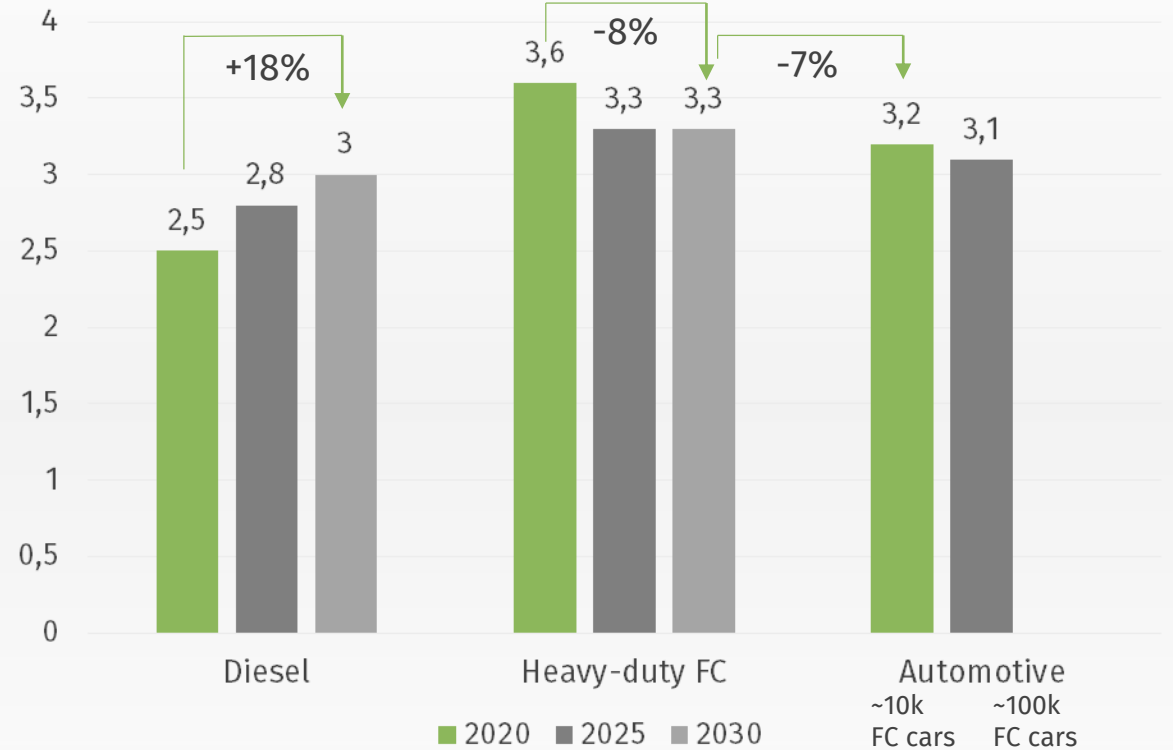

Analysis performed by Roland Berger for The Fuel Cells and Hydrogen Joint Undertaking (Figure 16), shows bus price perspectives in upcoming years and their TCO. It is strictly connected with passenger cars' market, where number of sold vehicles needs to be higher than 10 000 units per year.



**THANK YOU FOR  
YOUR ATTENTION >**

[www.solarisbus.com](http://www.solarisbus.com)

